

DINGS'

Precision Motion Specialist

SLOTLESS BLDC MOTOR

Jiangsu DINGS' Intelligent Control Technology Co., Ltd.





Founded in 2008, Jiangsu DINGS' Intelligent Control Technology Co., Ltd. is guided by the philosophy, **"Quality stems from responsibility, and details determine success."**

As a global leader in precision linear motion, DINGS' delivers a comprehensive portfolio of precision stepper, DC and BLDC motors, voice coil motors, lead and ball screw linear actuators, PMSM motors for eco-mobility, and advanced motion controllers — setting new benchmarks in the global motion control market.

SCALE

200+ Advanced Machining Equipment



20+ Automated Assembly Lines



100+ Precision Testing & Analysis Systems



140+ Patents & Intellectual Properties



GROWTH

2008 Company Founded & DINGS' Brand Established

2010 DINGS' Motion USA Established

2016 DINGS' Korea Established

2019 Joined LEILI Group

2021 Changzhou Intelligent Manufacturing Plant Established
Listed on China NEEQ Market

2022 Korea R&D Center Established

Listed on Beijing Stock Exchange [Stock Code: 920593]
2023 DINGS' Korea Converted to Corporate Entity
DINGS' Japan Established

2024 New Headquarters & Plant Established
DINGS' Motion Europe Established

2025 Thailand Manufacturing Facility Established

CERTIFICATIONS



PRODUCT WARRANTY

Warranty period: 1 year from shipment.

Free repair is provided for defects in materials or workmanship under normal use.

Warranty does not apply to:

- Warranty expiration or damaged/lost nameplates
- Improper installation or operating conditions
- Unauthorized disassembly or modification
- Repairs conducted outside of official service channels
- Force majeure, including natural disasters

DINGS' is committed to quality, reliability, and responsibility

— delivering high-performance motion solutions built on precision engineering.

Content

SLOTLESS BLDC MOTOR

Part Number Construction	4
6 mm	5
8 mm	7
10 mm	9
12mm	11
13 mm	13
14 mm	15
16 mm	17
22 mm	19
28 mm	21
30 mm	23
36 mm	25
42 mm	27
Precision planetary gearbox	29



Part Number Construction

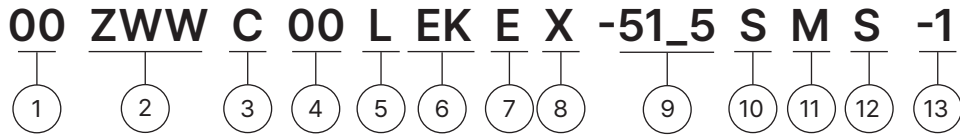

① Motor Size

Motor Size(mm)	6	8	10	12	13	14	16	22	28	30	36	42
----------------	---	---	----	----	----	----	----	----	----	----	----	----

② Product Name

ZWW = Slotless Brushless DC Motor

③ Motor Shape

C = Circular Type

S = Square Type

④ Motor Length

Unit : mm

when the length involves decimal points, use "_" instead

⑤ Motor Casing

L = Aluminum

T = Stainless steel / Iron

X = No housing

⑥ Option

EKX = Encoder (X = Encoder Resolution)

B = Brake

GX= Gearbox (X = Gear Ratio)

Note: When Options are not single,

please use in alphabetical order for example, "BEG"

⑦ Structure

E = External type

N = Non-Captive type

C = Electric Cylinder (Captive) type

K = Kaptive type

⑧ Lead Screw Code

Please refer to lead screw code selection table

⑨ Screw Length / Stroke

Kaptive = stroke distance

Non-captive = total length of screw

External = screw extension length from the mounting flange

⑩ Screw Surface Treatment

T = Teflon coating

S = Standard (No teflon coating)

⑪ End Machining

M = Metric

U = UNC

S = Smooth

C = Customize

N = None

⑫ Nut Style

S = Standard flange nut

A = Anti-backlash nut

C = Customized nut

⑬ Customer Sequence Number

Example

Part Number 16ZWWC40EK-001

Description Motor diameter 16mm
Slotless BLDC circular type
Body length 40mm
Encoder
Customization No.001

6mm Series

Motor Characteristics

Motor part number	6ZWWC20	
Pole pairs	-	1
Terminal resistance, Phase-Phase	Ω	5.9
Terminal inductance, Phase-Phase	mH	0.04
Winding connection method	-	Delta connection
Insulation class	-	B
Duty type	-	S2
Insulation strength (Withstand voltage)	-	300VAC/1KHz/1mA/1s
Insulation resistance	-	100M Ω /300VDC
Weight	g	3
Rated voltage	V	6
Rated power	W	1
Rated torque	mN·m	0.3
Rated speed	RPM	32000
Rated current	A	0.46
No load speed	RPM	48500
No load current	A	0.09
Motor efficiency	%	37
Noise (Ambient noise 20dB, test distance 1m)	dB	<50
Thermal Resistance (No-load)	K/W	39.9
Ambient temperature	$^{\circ}$ C	22.3
Max winding temperature	$^{\circ}$ C	63
Torque constant	mN·m/A	0.65
Back-EMF constant - peak value	V/Krpm	0.1
Back-EMF constant - effective value	V/Krpm	0.07
Peak torque	mN·m	0.66
Peak current	A	1
Rotor inertia	g·cm ²	0.005
Mechanical time constant	ms	6.92
End bell	-	Stainless steel
Bearing	-	Deep groove ball bearing
Magnet	-	Sinter NdFeB
Rotation shaft	-	Carbon steel

6mm Series

Dimensional Drawings

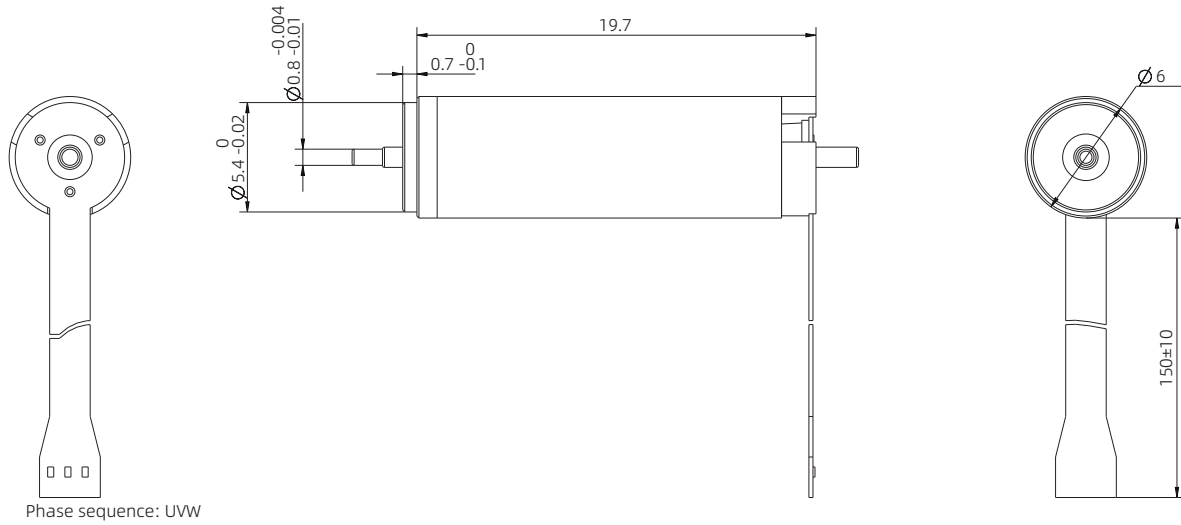

Torque Performance Curves

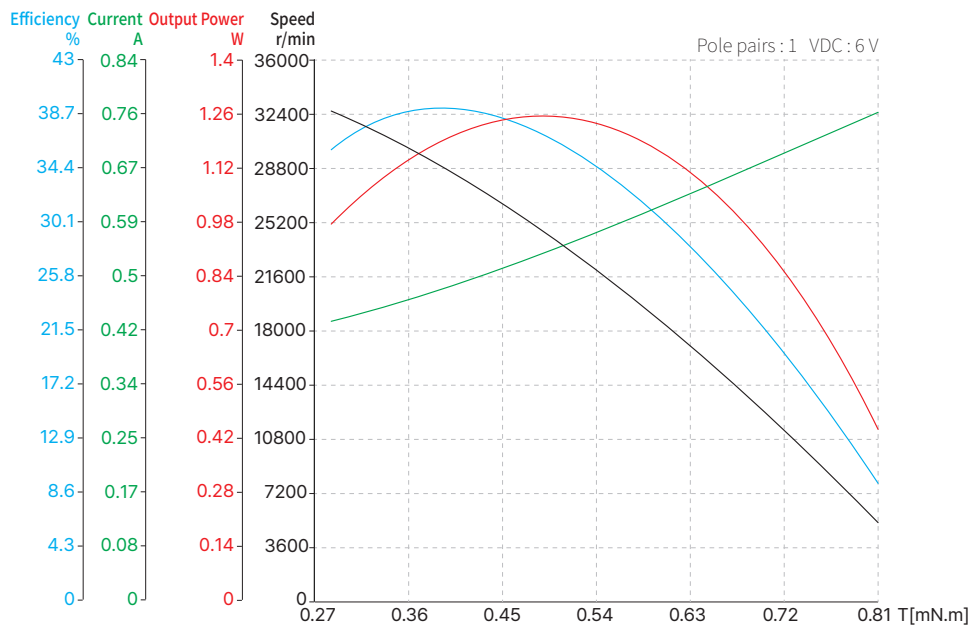

Motor Characteristics
8mm Series

Motor part number	8ZWWC25	
Pole pairs	-	1
Terminal resistance, Phase-Phase	Ω	6.1
Terminal inductance, Phase-Phase	mH	0.085
Winding connection method	-	Delta connection
Insulation class	-	B
Duty type	-	S2
Insulation strength (Withstand voltage)	-	300VAC/1KHz/1mA/1s
Insulation resistance	-	100M Ω /300VDC
Weight	g	7.3
Rated voltage	V	12
Rated power	W	3.25
Rated torque	mN·m	0.8
Rated speed	RPM	38200
Rated current	A	0.45
No load speed	RPM	48000
No load current	A	0.056
Motor efficiency	%	60
Noise (Ambient noise 20dB, test distance 1m)	dB	<50
Thermal Resistance (No-load)	K/W	12.52
Ambient temperature	$^{\circ}\text{C}$	22.3
Max winding temperature	$^{\circ}\text{C}$	63
Torque constant	mN·m/A	1.77
Back-EMF constant - peak value	V/Krpm	0.26
Back-EMF constant - effective value	V/Krpm	0.19
Peak torque	mN·m	3.49
Peak current	A	2
Rotor inertia	g·cm ²	0.016
Mechanical time constant	ms	3.11
End bell	-	Stainless steel
Bearing	-	Deep groove ball bearing
Magnet	-	Sinter NdFeB
Rotation shaft	-	Carbon steel

For customized options, please contact DINGS' or your local distributor

8mm Series

Dimensional Drawings

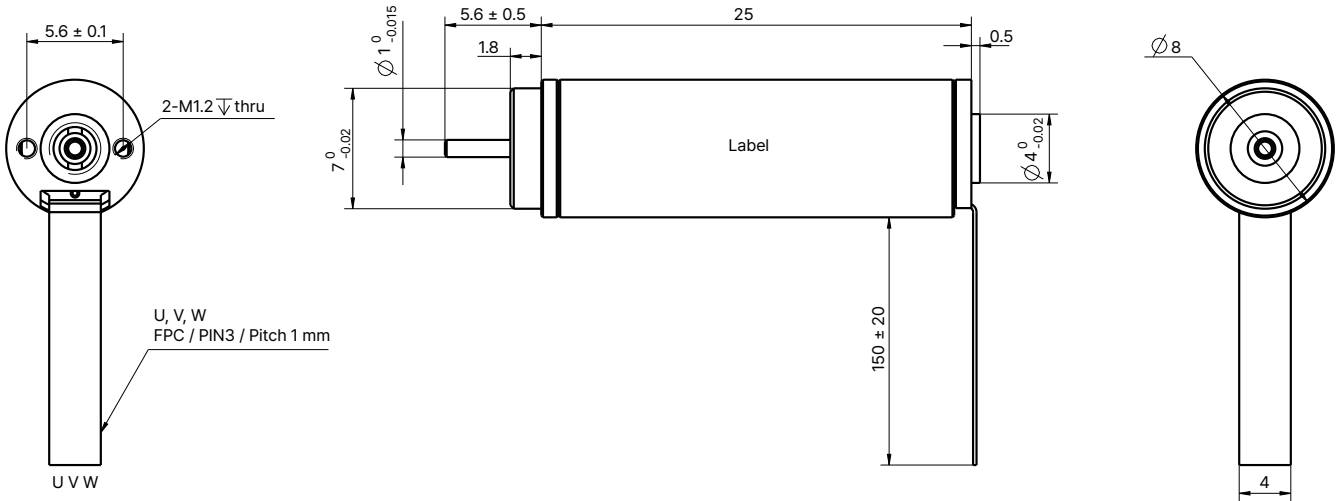

Torque Performance Curves

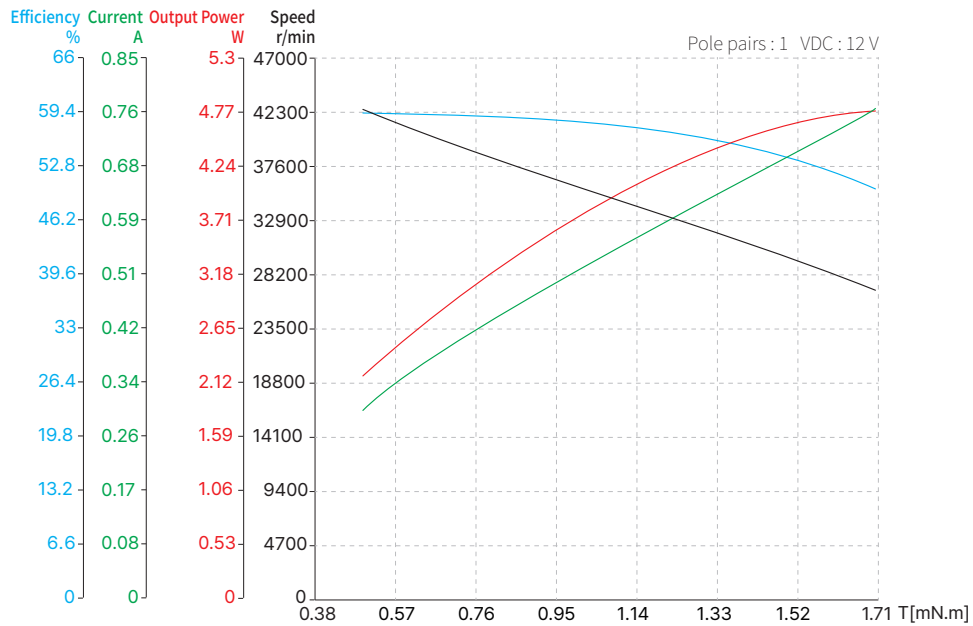

Note : All drawings are 1st Angle Projection - ISO Compliant (3D models available)

10mm Series

Motor Characteristics

Motor part number	10ZWWC26	
Pole pairs	-	1
Terminal resistance, Phase-Phase	Ω	4.5
Terminal inductance, Phase-Phase	mH	0.15
Winding connection method	-	Delta connection
Insulation class	-	B
Duty type	-	S2
Feedback method	-	Hall sensor
Commutation angle	-	120°
Insulation strength (Withstand voltage)	-	300VAC/1KHz/1mA/1s
Insulation resistance	-	100M Ω /300VDC
Weight	g	14.3
Rated voltage	V	12
Rated power	W	5
Rated torque	mN·m	1.5
Rated speed	RPM	28500
Rated current	A	0.56
No load speed	RPM	35000
No load current	A	0.065
Motor efficiency	%	67
Noise (Ambient noise 20dB, test distance 1m)	dB	<50
Thermal Resistance (No-load)	K/W	10.6
Ambient temperature	°C	22.3
Max winding temperature	°C	70
Torque constant	mN·m/A	2.68
Back-EMF constant - peak value	V/Krpm	0.4
Back-EMF constant - effective value	V/Krpm	0.28
Peak torque	mN·m	7.15
Peak current	A	3
Rotor inertia	g·cm ²	0.026
Mechanical time constant	ms	1.63
End bell	-	Stainless steel
Bearing	-	Deep groove ball bearing
Magnet	-	Sinter NdFeB
Rotation shaft	-	Carbon steel

10mm Series

Dimensional Drawings

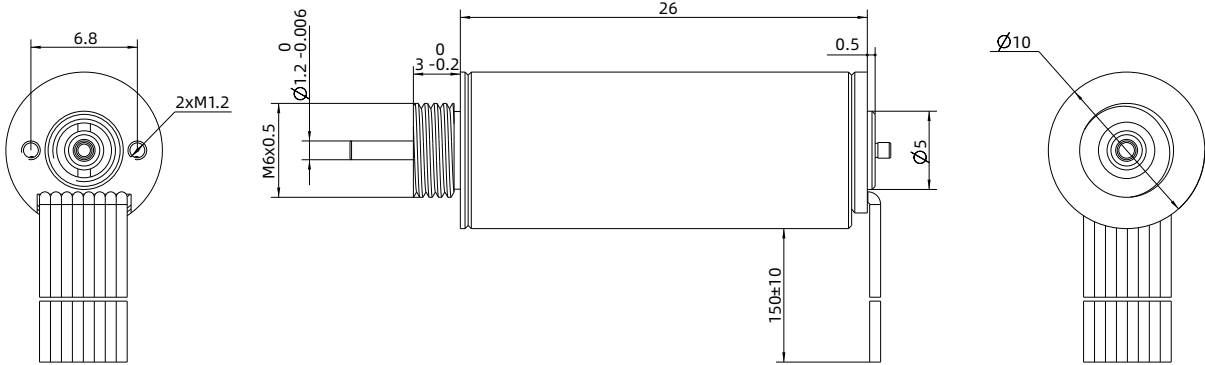

Torque Performance Curves

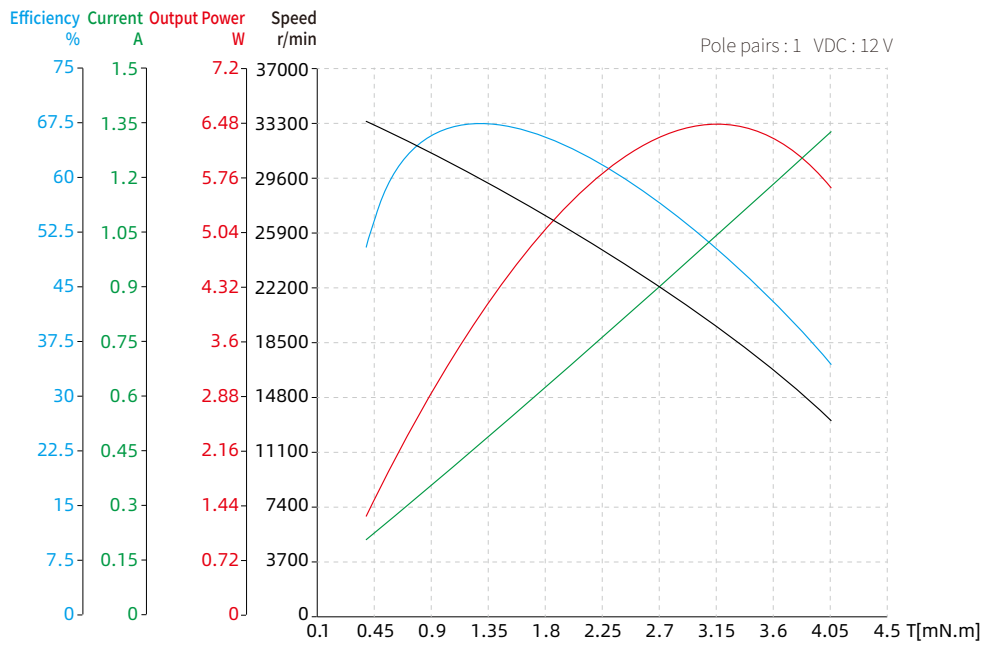

12mm Series

Motor Characteristics

Motor part number	12ZWWC29	
Pole pairs	-	2
Terminal resistance, Phase-Phase	Ω	1
Terminal inductance, Phase-Phase	mH	0.033
Winding connection method	-	Star connection
Insulation class	-	B
Duty type	-	S2
Insulation strength (Withstand voltage)	-	660VAC/1KHz/1mA/1s
Insulation resistance	-	100M Ω /500VDC
Weight	g	16.5
Rated voltage	V	6
Rated power	W	5
Rated torque	mN·m	4
Rated speed	RPM	12000
Rated current	A	1.21
No load speed	RPM	15000
No load current	A	0.16
Motor efficiency	%	70
Noise (Ambient noise 20dB, test distance 1m)	dB	<50
Thermal Resistance (No-load)	K/W	12.49
Ambient temperature	$^{\circ}\text{C}$	22.3
Max winding temperature	$^{\circ}\text{C}$	86
Torque constant	mN·m/A	3.29
Back-EMF constant - peak value	V/Krpm	0.49
Back-EMF constant - effective value	V/Krpm	0.34
Peak torque	mN·m	19.76
Peak current	A	6
Rotor inertia	g·cm ²	0.3
Mechanical time constant	ms	2.76
End bell	-	Aluminum alloy
Bearing	-	Deep groove ball bearing
Magnet	-	Sinter NdFeB
Rotation shaft	-	Carbon steel

12mm Series

Dimensional Drawings

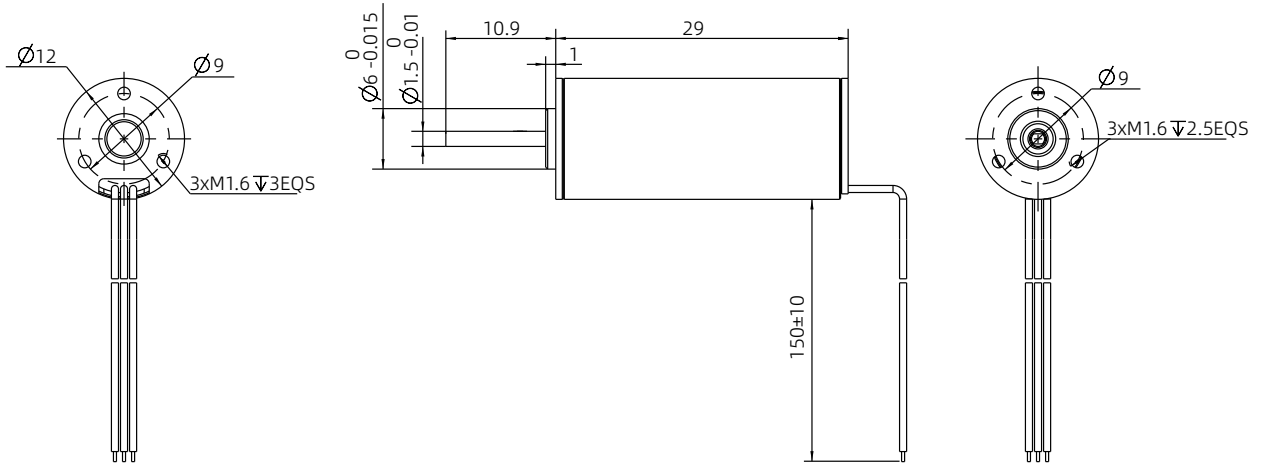

Torque Performance Curves

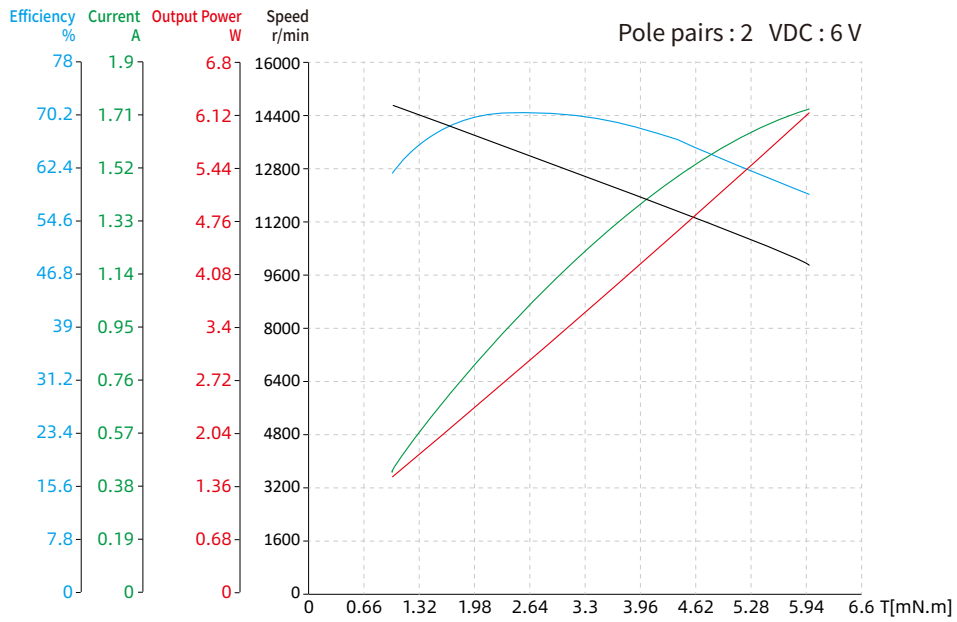

13mm Series

Motor Characteristics

Motor part number	13ZWWC37	
Pole pairs	-	1
Terminal resistance, Phase-Phase	Ω	3.65
Terminal inductance, Phase-Phase	mH	0.113
Winding connection method	-	Delta connection
Insulation class	-	B
Duty type	-	S2
Feedback method	-	Hall sensor
Commutation angle	-	120°
Insulation strength (Withstand voltage)	-	300VAC/1KHz/1mA/1s
Insulation resistance	-	100M Ω /300VDC
Weight	g	28.6
Rated voltage	V	24
Rated power	W	11
Rated torque	mN·m	2.7
Rated speed	RPM	43500
Rated current	A	0.66
No load speed	RPM	46800
No load current	A	0.086
Motor efficiency	%	69
Noise (Ambient noise 20dB, test distance 1m)	dB	<50
Thermal Resistance (No-load)	K/W	3.70
Ambient temperature	°C	22.3
Max winding temperature	°C	63
Torque constant	mN·m/A	4.06
Back-EMF constant - peak value	V/Krpm	0.6
Back-EMF constant - effective value	V/Krpm	0.43
Peak torque	mN·m	26.73
Peak current	A	7
Rotor inertia	g·cm ²	0.14
Mechanical time constant	ms	3.09
End bell	-	Stainless steel
Bearing	-	Deep groove ball bearing
Magnet	-	Sinter NdFeB
Rotation shaft	-	Carbon steel

13mm Series

Dimensional Drawings

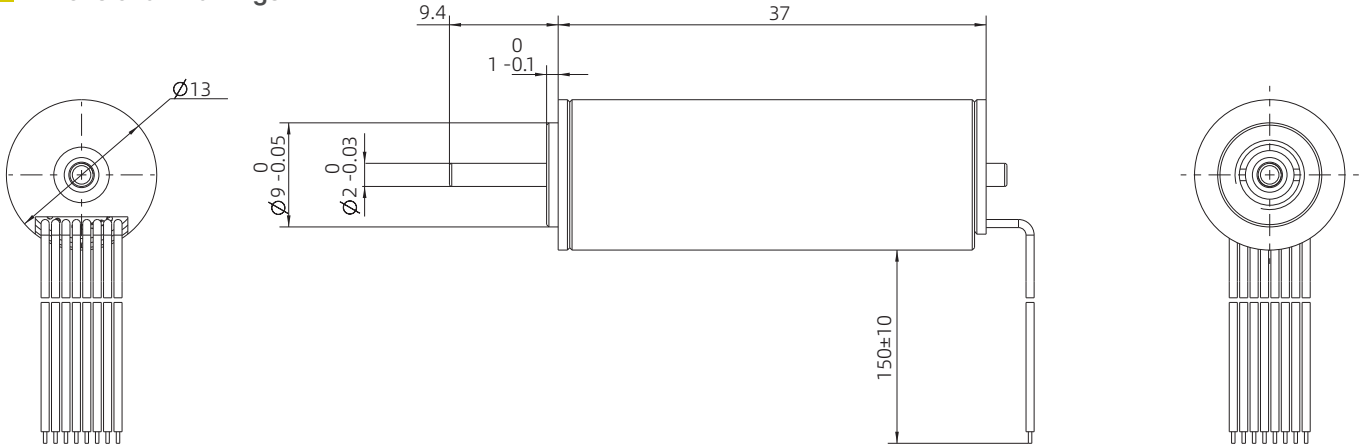

Torque Performance Curves

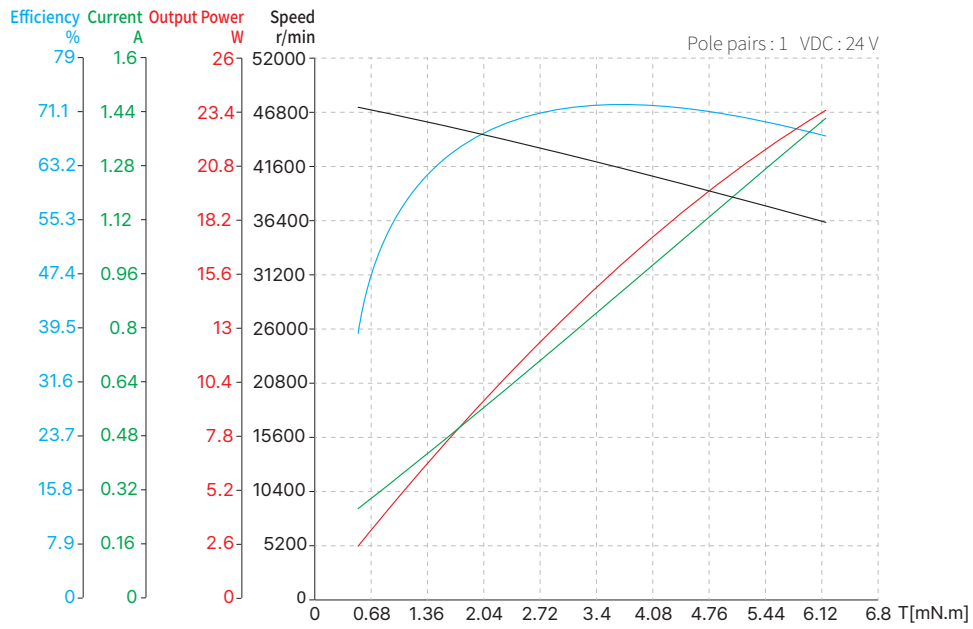

14mm Series

Motor Characteristics

Motor part number	14ZWWC36	
Pole pairs	-	1
Terminal resistance, Phase-Phase	Ω	0.87
Terminal inductance, Phase-Phase	mH	0.04
Winding connection method	-	Delta connection
Insulation class	-	B
Duty type	-	S1
Feedback method	-	Hall sensor
Commutation angle	-	120°
Insulation strength (Withstand voltage)	-	500VAC/1KHz/1mA/1s
Insulation resistance	-	100MΩ/500VDC
Weight	g	34.2
Rated voltage	V	6
Rated power	W	5.1
Rated torque	mN·m	4
Rated speed	RPM	12152
Rated current	A	1.3
No load speed	RPM	15000
No load current	A	0.18
Motor efficiency	%	66
Noise (Ambient noise 20dB, test distance 1m)	dB	<50
Thermal Resistance (No-load)	K/W	9.35
Ambient temperature	°C	22.3
Max winding temperature	°C	70
Torque constant	mN·m/A	3.08
Back-EMF constant - peak value	V/Krpm	0.46
Back-EMF constant - effective value	V/Krpm	0.32
Peak torque	mN·m	20
Peak current	A	6
Rotor inertia	g·cm ²	0.15
Mechanical time constant	ms	1.38
End bell	-	Stainless steel
Bearing	-	Deep groove ball bearing
Magnet	-	Sinter NdFeB
Rotation shaft	-	Carbon steel

14mm Series

Dimensional Drawings

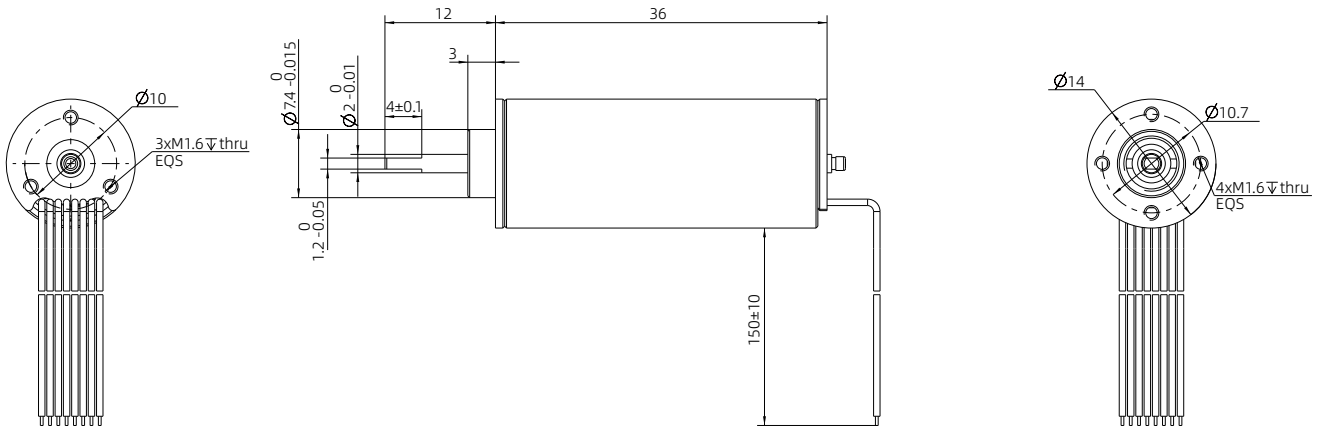

Torque Performance Curves

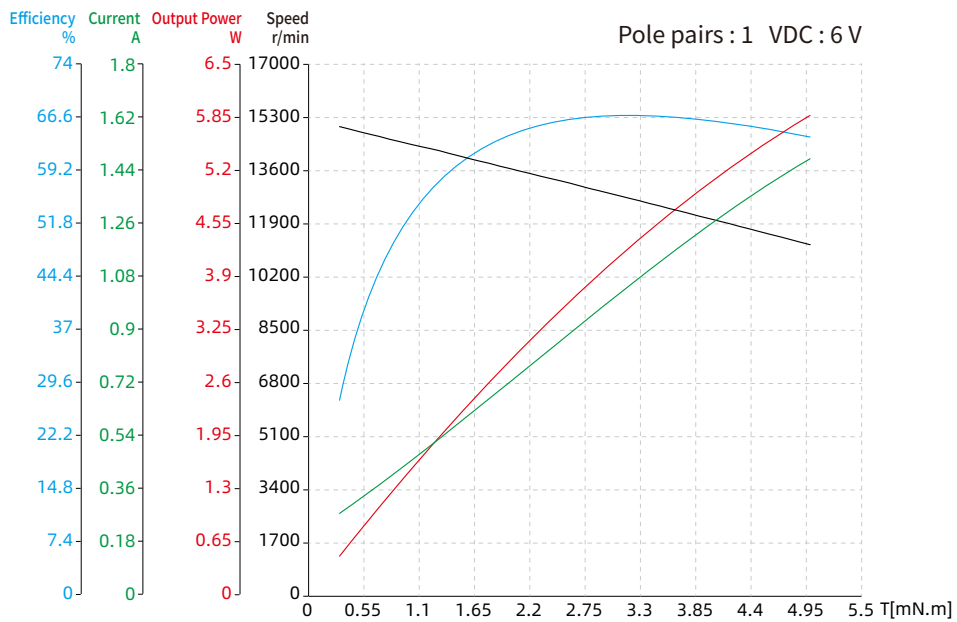

16mm Series

Motor Characteristics

Motor part number		16ZWWC24-1SZ	16ZWWC40					16ZWWC56-5SZ
Pole pairs	-	1	1	1	1	1	1	1
Terminal resistance, Phase-Phase	Ω	2.408	0.63	1.31	1.85	3.15	0.3196	0.4971
Terminal inductance, Phase-Phase	mH	0.067	0.033	0.045	0.096	0.2	0.014	0.033
Winding connection method	-	Delta connection	Star connection	Star connection	Star connection	Star connection	Delta connection	Star connection
Insulation class	-	B	B	B	B	B	B	B
Duty type	-	S2	S2	S2	S2	S2	S2	S2
Feedback method	-	Hall sensor	Hall sensor	Hall sensor	Hall sensor	Hall sensor	Hall sensor	Hall sensor
Commutation angle	-	120°	120°	120°	120°	120°	120°	120°
Insulation strength (Withstand voltage)	-	500VAC/1KHz/1mA/1s						
Insulation resistance	-	100MΩ/500VDC						
Weight	g	26.5	47	47	47	47	47	63
Rated voltage	V	12	18	24	36	48	12	24
Rated power	W	10.8	33	39	39	39	27.26	73.5
Rated torque	mN·m	3.2	7.4	7.4	7.5	7.4	7.5	14.6
Rated speed	RPM	32300	44000	51300	50000	50000	34700	48100
Rated current	A	1.21	2.19	1.96	1.32	0.95	3	3.81
No load speed	RPM	44000	50000	58000	56000	56000	40000	54000
No load current	A	0.35	0.31	0.22	0.15	0.12	0.4	0.5
Motor efficiency	%	75.5	85	84	82.4	84.92	81.4	87.1
Noise (Ambient noise 20dB, test distance 1m)	dB	<50	<50	<50	<50	<50	<50	<50
Thermal Resistance (No-load)	K/W	-	1.22	1.33	1.47	1.07	-	-
Thermal Time Constant (No-load)	S	-	420	450	480	390	-	-
Ambient temperature	°C	22.3	22.3	22.3	22.3	22.3	22.3	22.3
Max winding temperature (No-load)	°C	-	63	75	80	63.8	-	-
Torque constant	mN·m/A	2.6	3.38	3.78	5.66	7.75	2.86	4.24
Back-EMF constant - peak value	V/Krpm	0.38	0.50	0.56	0.84	1.15	0.42	0.62
Back-EMF constant - effective value	V/Krpm	0.27	0.35	0.40	0.59	0.81	0.3	0.44
Peak torque	mN·m	9	96.65	69.21	110.19	118.13	53	140
Peak current	A	4.9	29	18	19	15	19	39
Rotor inertia	g·cm ²	0.3	0.583	0.583	0.583	0.583	0.58	0.8
Mechanical time constant	ms	10.69	3.21	5.35	3.36	3.06	2.28	2.21
End bell	-	Stainless steel						
Bearing	-	Deep groove ball bearing						
Magnet	-	Sinter NdFeB						
Rotation shaft	-	Carbon steel						

16mm Series

Dimensional Drawings

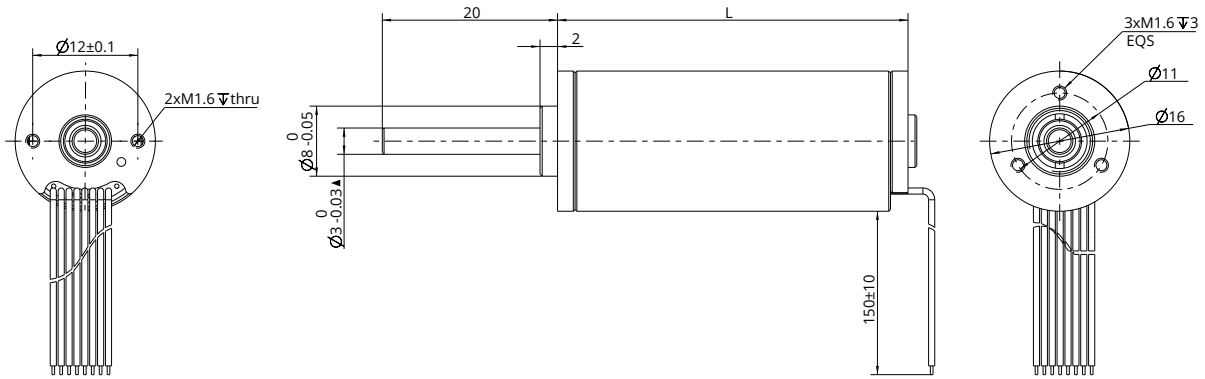

Torque Performance Curves

16ZWWC24

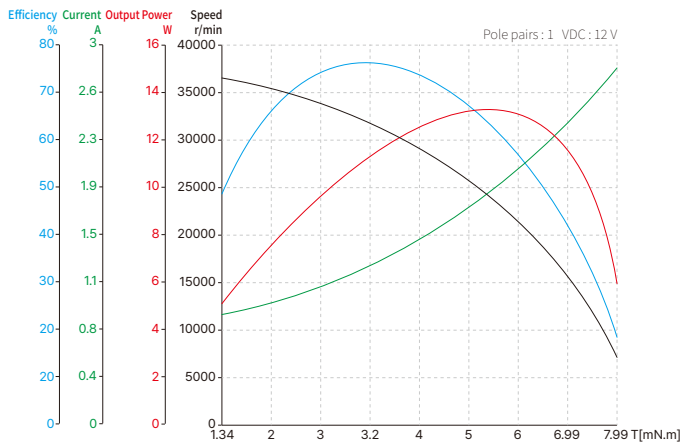

16ZWWC40

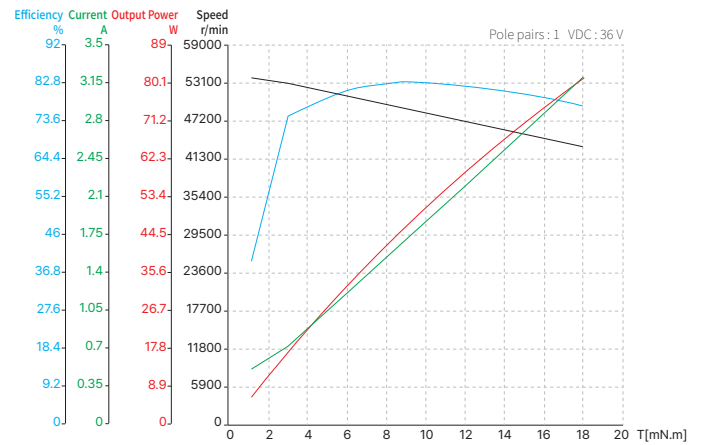

16ZWWC56

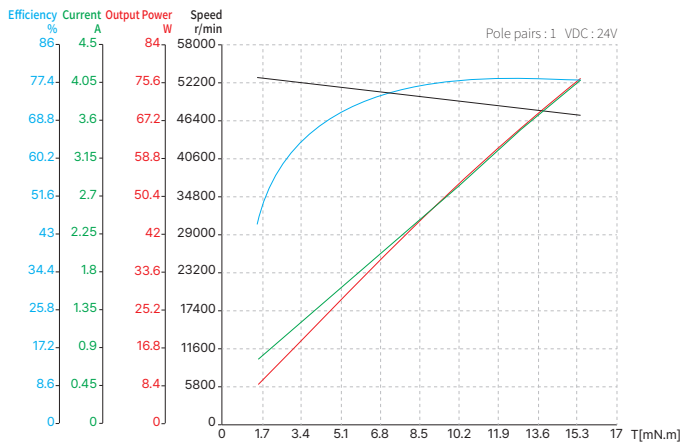

22mm Series

Motor Characteristics

Motor part number		22ZWWC48					22ZWWC64-1SZ
Pole pairs	-	1	1	1	1	2	1
Terminal resistance, Phase-Phase	Ω	0.26	0.3	0.57	1	0.94	0.63
Terminal inductance, Phase-Phase	mH	0.018	0.027	0.06	0.11	0.057	0.061
Winding connection method	-	Star connection	Star connection	Star connection	Star connection	Star connection	Star connection
Insulation class	-	B	B	B	B	B	B
Duty type	-	S2	S2	S2	S2	S1	S2
Feedback method	-	Hall sensor	Hall sensor	Hall sensor	Hall sensor	Hall sensor	Hall sensor
Commutation angle	-	120°	120°	120°	120°	120°	120°
Insulation strength (Withstand voltage)	-	500VAC/1KHz/1mA/1s					
Insulation resistance	-	100MΩ/ 500VDC					
Weight	g	110	110	110	110	110	140
Rated voltage	V	18	24	36	48	24	24
Rated power	W	83	100	100	100	53	38.24
Rated torque	mN·m	20	20	20	20	25	20
Rated speed	RPM	40000	49000	47400	49600	20100	18200
Rated current	A	7.95	4.68	3.12	2.29	3	1.86
No load speed	RPM	50000	55000	53000	54000	25700	19300
No load current	A	0.3	0.4	0.32	0.14	0.18	0.126
Motor efficiency	%	87	89	89	91	81	89.7
Noise (Ambient noise 20dB, test distance 1m)	dB	<50	<50	<50	<50	<50	< 50
Thermal Resistance (No-load)	K/W	0.38	0.58	0.51	0.42	1.12	-
Thermal Time Constant (No-load)	S	840	600	900	1200	620	-
Ambient temperature	°C	21.4	22	24.7	21.1	23.3	22.3
Max winding temperature (No-load)	°C	52.7	80	75.5	70.5	82	-
Torque constant	mN·m/A	2.52	4.27	6.41	8.74	8.33	11.87
Back-EMF constant - peak value	V/Krpm	0.37	0.63	0.95	1.29	1.23	1.758
Back-EMF constant - effective value	V/Krpm	0.26	0.45	0.67	0.91	0.87	1.24
Peak torque	mN·m	116.11	341.76	404.72	419.33	212.77	320
Peak current	A	46	80	63	48	26	33.5
Rotor inertia	g·cm ²	1.15	1.15	1.15	1.15	1.15	3
Mechanical time constant	ms	4.72	1.89	1.60	1.51	1.56	1.34
End bell	-	Stainless steel					
Bearing	-	Deep groove ball bearing					
Magnet	-	Sinter NdFeB					
Rotation shaft	-	Carbon steel					

22mm Series

Dimensional Drawings

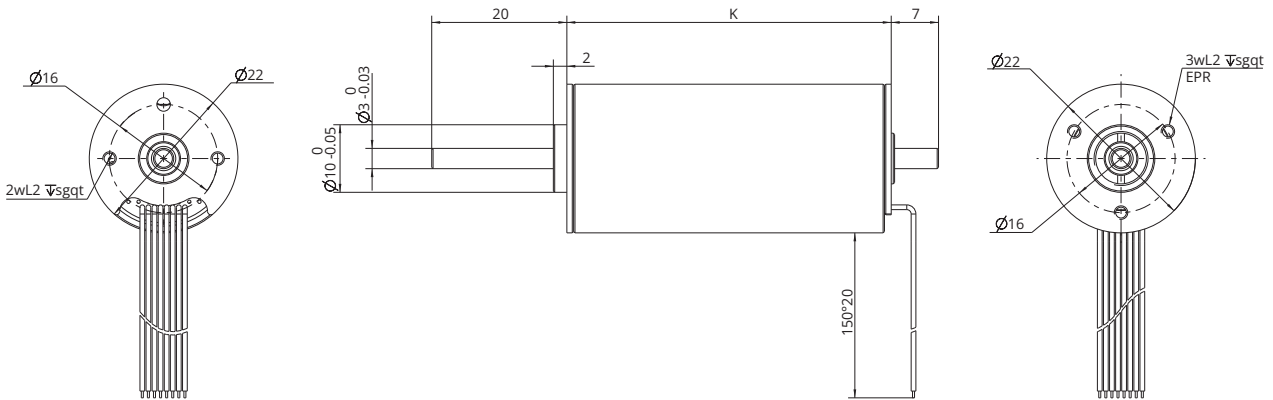

Torque Performance Curves

● 22ZWWC48

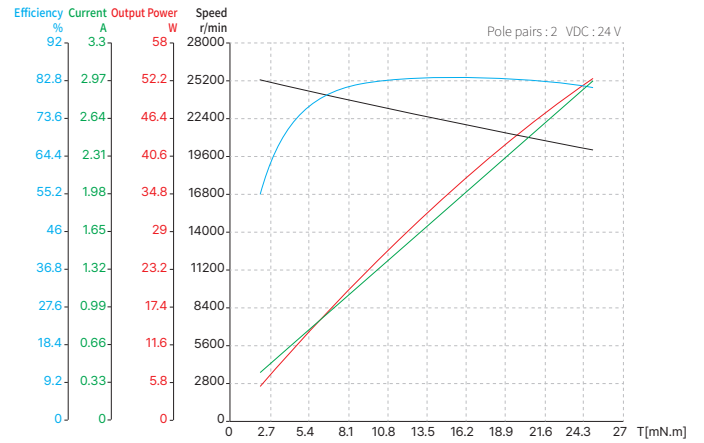
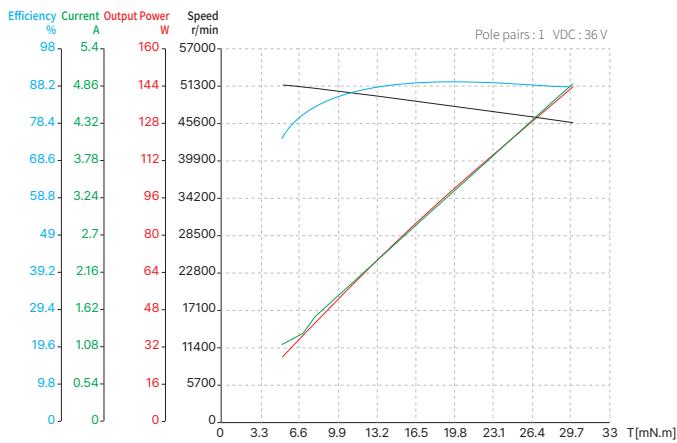

● 22ZWWC64

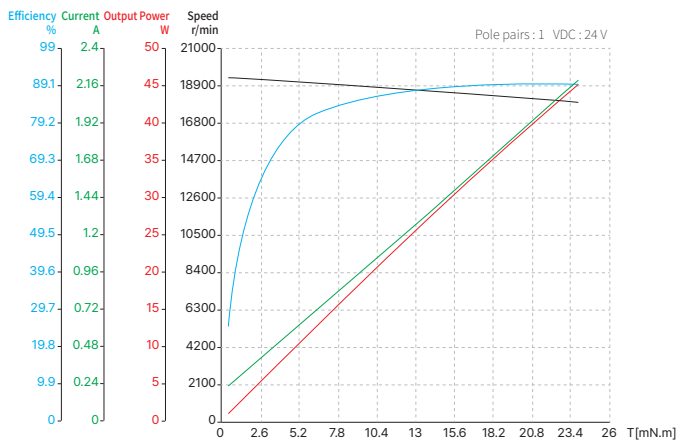

28mm Series

Motor Characteristics

Motor part number	28ZWWC52					
Pole pairs	-	1	1	1	1	2
Terminal resistance, Phase-Phase	Ω	0.52	1.7	4.3	6.6	1.6
Terminal inductance, Phase-Phase	mH	0.0495	0.178	0.42	0.77	0.13
Winding connection method	-	Star connection	Star connection	Star connection	Star connection	Star connection
Insulation class	-	B	B	B	B	B
Duty type	-	S2	S2	S2	S2	S1
Feedback method	-	Hall sensors	Hall sensors	Hall sensors	Hall sensors	Hall sensors
Commutation angle	-	120°	120°	120°	120°	120°
Insulation strength (Withstand voltage)	-	500VAC/1KHz/1mA/1s				
Insulation resistance	-	100MΩ/500VDC				
Weight	g	170	170	170	170	170
Rated voltage	V	12	24	36	48	24
Rated power	W	30	34	35	35	37
Rated torque	mN·m	32	32	32	34	50
Rated speed	RPM	6970	8430	8370	8340	7000
Rated current	A	3.13	1.69	1.17	0.86	2.00
No load speed	RPM	9270	9680	9500	9400	8500
No load current	A	0.2	0.11	0.084	0.061	0.12
Motor efficiency	%	80	84	83	85	81.5
Noise (Ambient noise 20dB, test distance 1m)	dB	<50	<50	<50	<50	<50
Thermal Resistance (No-load)	K/W	0.67	0.69	0.73	0.64	0.70
Thermal Time Constant (No-load)	S	1200	1200	1080	1100	880
Ambient temperature	°C	23	24	27	25	21.2
Max winding temperature (No-load)	°C	43.2	47.3	52.5	47.4	46.7
Torque constant	mN·m/A	10.24	18.97	27.32	39.63	25
Back-EMF constant - peak value	V/Krpm	1.52	2.81	4.04	5.87	3.70
Back-EMF constant - effective value	V/Krpm	1.07	1.99	2.86	4.15	2.62
Peak torque	mN·m	236.31	267.87	228.72	288.25	375
Peak current	A	23	14	8	7	15
Rotor inertia	g·cm ²	10.2	10.2	10.2	10.2	10.2
Mechanical time constant	ms	5.06	4.82	5.88	4.29	2.61
End bell	-	Stainless steel				
Bearing	-	Deep groove ball bearing				
Magnet	-	Sinter NdFeB				
Rotation shaft	-	Carbon steel				

28mm Series

Dimensional Drawings

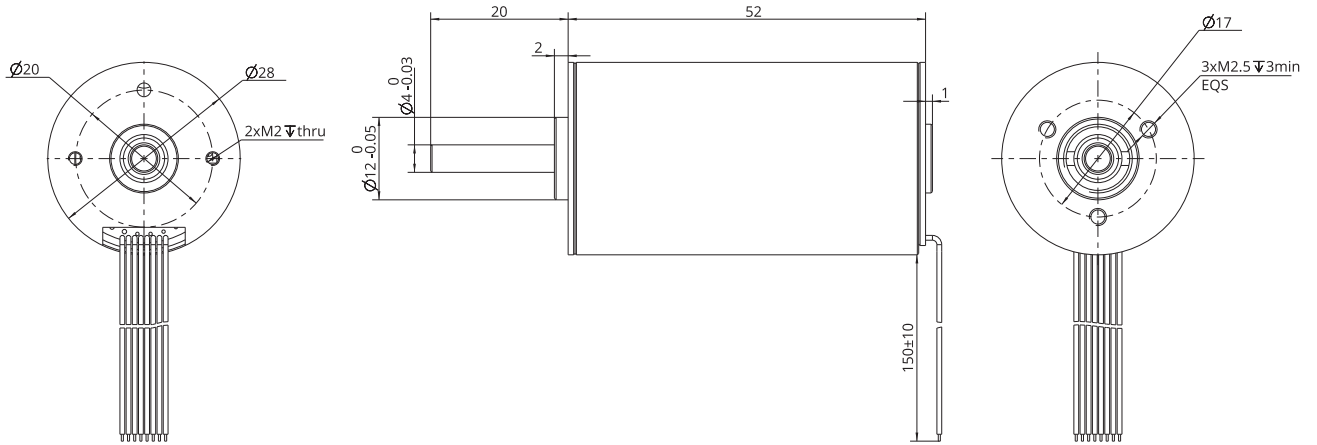

Torque Performance Curves

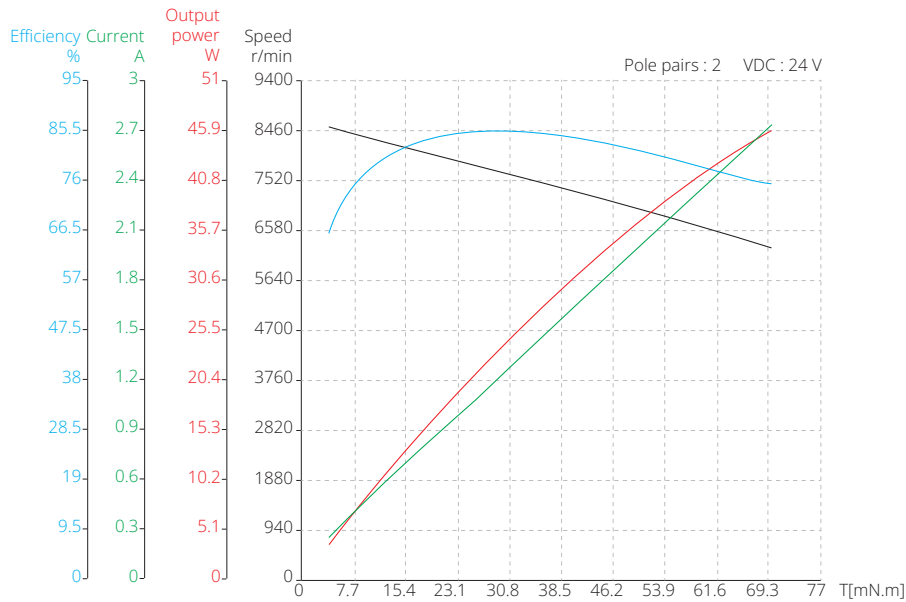
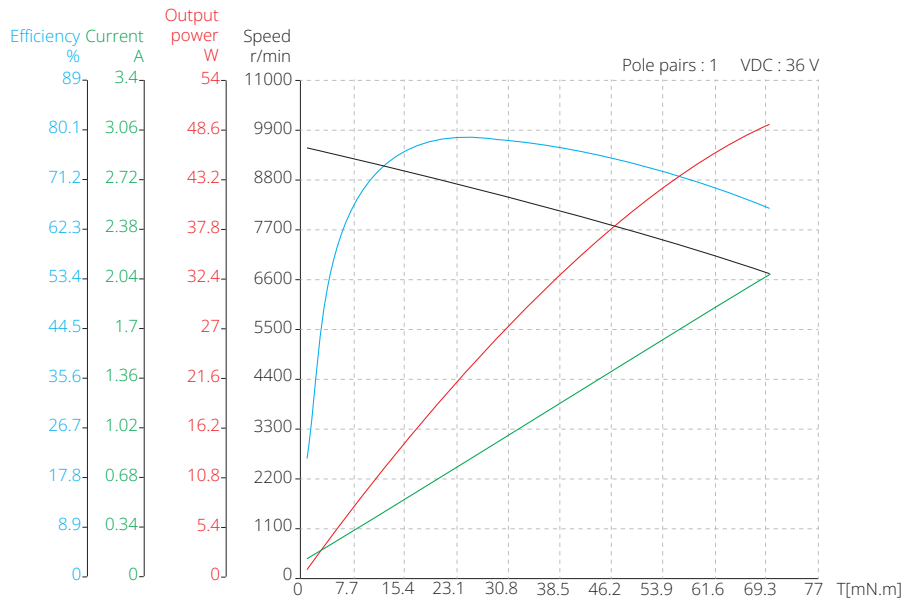

30mm Series

Motor Characteristics

Motor part number	30ZWWC65	
Pole pairs	-	2
Terminal resistance, Phase-Phase	Ω	0.5
Terminal inductance, Phase-Phase	mH	0.05
Winding connection method	-	Star connection
Insulation class	-	B
Duty type	-	S1
Feedback method	-	Hall sensors
Commutation angle	-	120°
Insulation strength (Withstand voltage)	-	500VAC/1KHz/1mA/1s
Insulation resistance	-	100M Ω /500VDC
Weight	g	230
Rated voltage	V	24
Rated power	W	65
Rated torque	mN·m	90
Rated speed	RPM	6900
Rated current	A	3.85
No load speed	RPM	9200
No load current	A	0.3
Motor efficiency	%	86
Noise (Ambient noise 20dB, test distance 1m)	dB	<50
Thermal Resistance (No-load)	K/W	0.31
Thermal Time Constant (No-load)	S	1200
Ambient temperature	°C	23
Max winding temperature (No-load)	°C	43.2
Torque constant	mN·m/A	23.38
Back-EMF constant - peak value	V/Krpm	3.46
Back-EMF constant - effective value	V/Krpm	2.45
Peak torque	mN·m	1122.08
Peak current	A	48
Rotor inertia	g·cm ²	28
Mechanical time constant	ms	2.56
End bell	-	Stainless steel
Bearing	-	Deep groove ball bearing
Magnet	-	Sinter NdFeB
Rotation shaft	-	Carbon steel

30mm Series

Dimensional Drawings

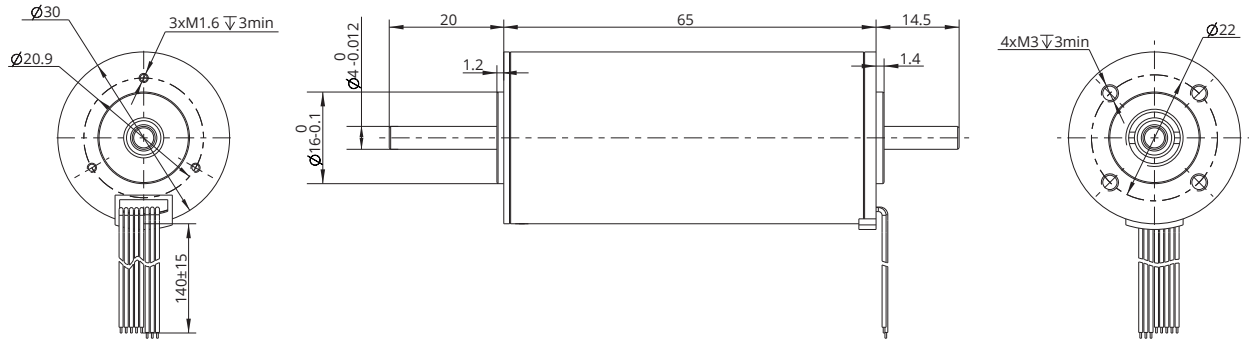

Torque Performance Curves

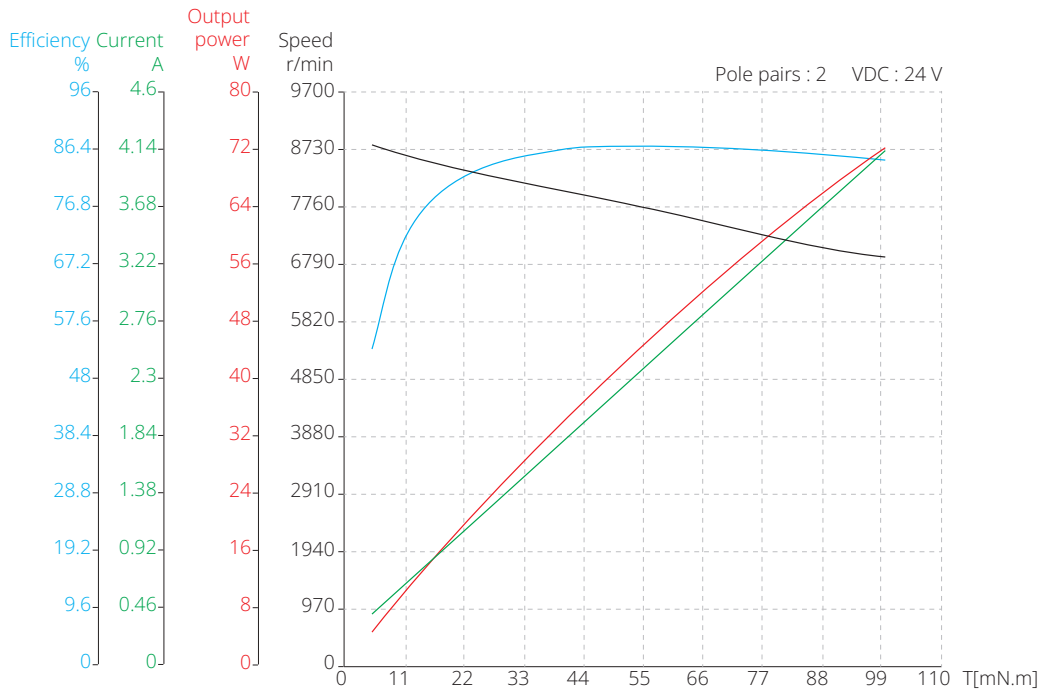

36mm Series

Motor Characteristics

Motor part number	36ZWWC60					
Pole pairs	-	1	1	1	1	2
Terminal resistance, Phase-Phase	Ω	0.6	0.68	1.45	2.1	0.41
Terminal inductance, Phase-Phase	mH	0.08	0.1	0.19	0.27	0.042
Winding connection method	-	Star connection	Star connection	Star connection	Star connection	Star connection
Insulation class	-	B	B	B	B	B
Duty type	-	S2	S2	S2	S2	S1
Feedback method	-	Hall sensors	Hall sensors	Hall sensors	Hall sensors	Hall sensors
Commutation angle	-	120°	120°	120°	120°	120°
Insulation strength (Withstand voltage)	-	500VAC/1KHz/1mA/1s				
Insulation resistance	-	100MΩ/500VDC				
Weight	g	270	270	270	270	270
Rated voltage	V	18	24	36	48	24
Rated power	W	68	69	74	85	85
Rated torque	mN·m	70	70	70	70	100
Rated speed	RPM	7340	9345	10000	11700	8100
Rated current	A	4.97	3.78	2.59	2.21	4.80
No load speed	RPM	10000	11000	11500	13000	10300
No load current	A	0.37	0.37	0.22	0.2	0.36
Motor efficiency	%	76	76	79.5	80	84.4
Noise (Ambient noise 20dB, test distance 1m)	dB	<50	<50	<50	<50	<50
Thermal Resistance (No-load)	K/W	0.42	0.43	0.44	0.36	0.58
Thermal Time Constant (No-load)	S	1350	1350	2700	1080	1330
Ambient temperature	°C	21.1	23.1	20.1	20.4	19.5
Max winding temperature (No-load)	°C	49.4	52.9	52.8	50.8	69.3
Torque constant	mN·m/A	14.08	18.50	27.07	31.62	20.83
Back-EMF constant - peak value	V/Krpm	2.09	2.74	4.01	4.68	3.08
Back-EMF constant - effective value	V/Krpm	1.47	1.94	2.83	3.31	2.18
Peak torque	mN·m	422.47	653.09	672.16	722.82	1219.51
Peak current	A	30	35	25	23	59
Rotor inertia	g·cm ²	39	39	39	39	39
Mechanical time constant	ms	11.80	7.75	7.72	8.19	3.68
End bell	-	Stainless steel				
Bearing	-	Deep groove ball bearing				
Magnet	-	Sinter NdFeB				
Rotation shaft	-	Carbon steel				

36mm Series

Dimensional Drawings

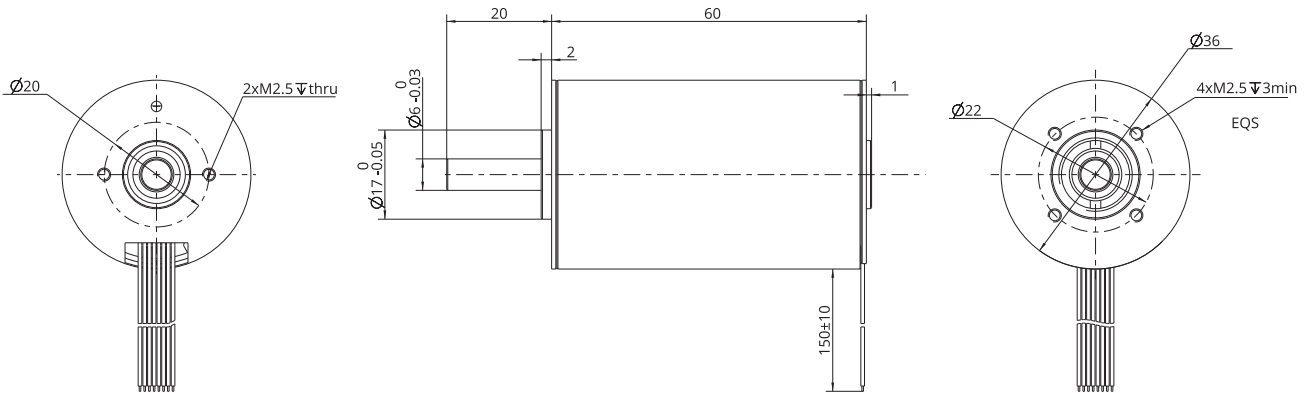

Torque Performance Curves

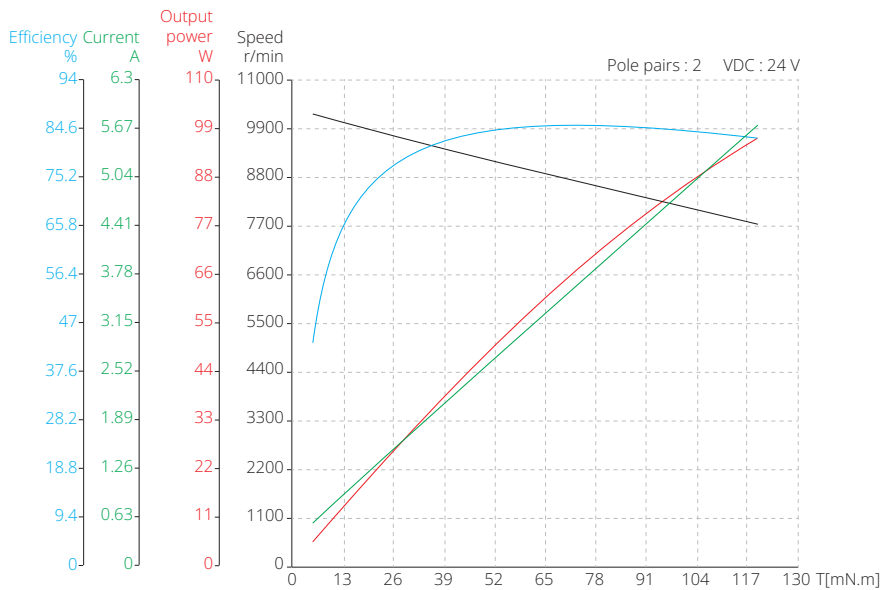
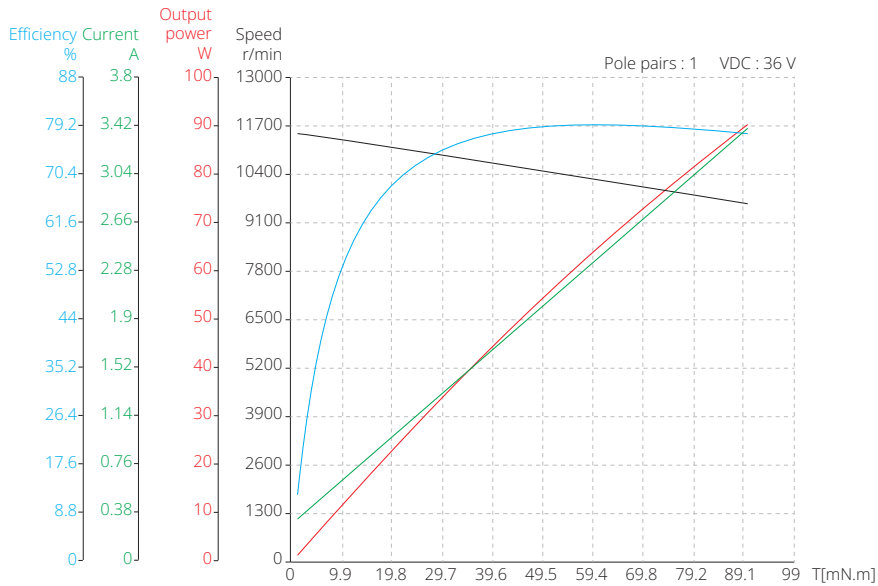

42mm Series

Motor Characteristics

Motor part number	42ZWWC80					
Pole pairs	-	1	1	1	1	2
Terminal resistance, Phase-Phase	Ω	0.4	0.45	0.6	0.95	0.22
Terminal inductance, Phase-Phase	mH	0.085	0.14	0.14	0.23	0.035
Winding connection method	-	Star connection	Star connection	Star connection	Star connection	Star connection
Insulation class	-	B	B	B	B	B
Duty type	-	S2	S2	S2	S2	S1
Feedback method	-	Hall sensors	Hall sensors	Hall sensors	Hall sensors	Hall sensors
Commutation angle	-	120°	120°	120°	120°	120°
Insulation strength (Withstand voltage)	-	500VAC/1KHz/1mA/1s				
Insulation resistance	-	100MΩ/500VDC				
Weight	g	500	500	500	500	500
Rated voltage	V	18	24	36	48	24
Rated power	W	66	80	100	160	102
Rated torque	mN·m	90	90	90	120	180
Rated speed	RPM	6678	8346	11619	12200	5400
Rated current	A	4.89	4.17	3.47	4.17	5.70
No load speed	RPM	9000	11000	13000	13800	6800
No load current	A	0.6	0.69	0.6	0.58	0.42
Motor efficiency	%	75	80	80	80	87.9
Noise (Ambient noise 20dB, test distance 1m)	dB	<50	<50	<50	<50	<50
Thermal Resistance (No-load)	K/W	0.43	0.50	0.67	0.26	0.41
Thermal Time Constant (No-load)	S	900	1620	2040	2040	1340
Ambient temperature	°C	23.1	23.5	23	23	22.6
Max winding temperature (No-load)	°C	51.5	63.7	90	90	72.1
Torque constant	mN·m/A	18.41	21.60	25.92	28.80	31.58
Back-EMF constant - peak value	V/Krpm	2.73	3.20	3.84	4.26	4.68
Back-EMF constant - effective value	V/Krpm	1.93	2.26	2.71	3.02	3.31
Peak torque	mN·m	828.41	1152.00	1555.20	1455.16	3444.98
Peak current	A	45	53	60	51	109
Rotor inertia	g·cm ²	96.3	96.3	96.3	96.3	96.3
Mechanical time constant	ms	11.37	9.29	8.60	11.03	2.12
End bell	-	Stainless steel				
Bearing	-	Deep groove ball bearing				
Magnet	-	Sinter NdFeB				
Rotation shaft	-	Carbon steel				

42mm Series

Dimensional Drawings

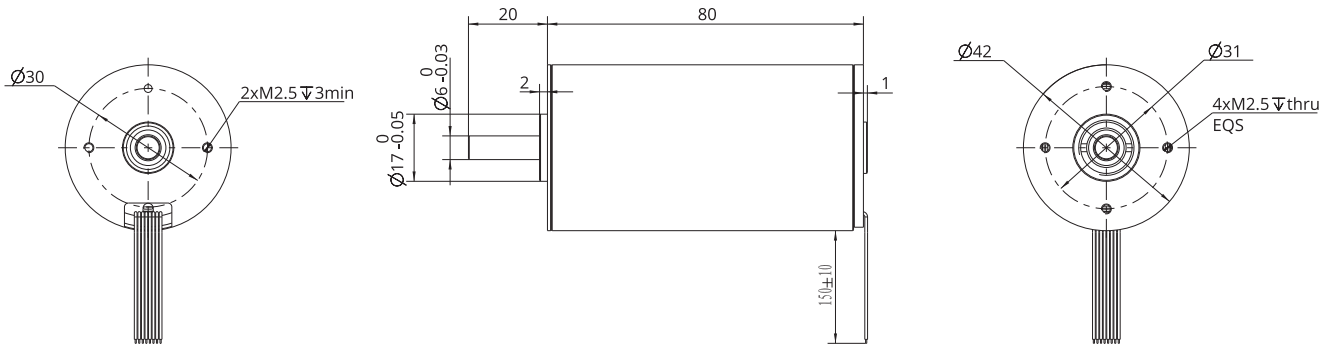

Torque Performance Curves

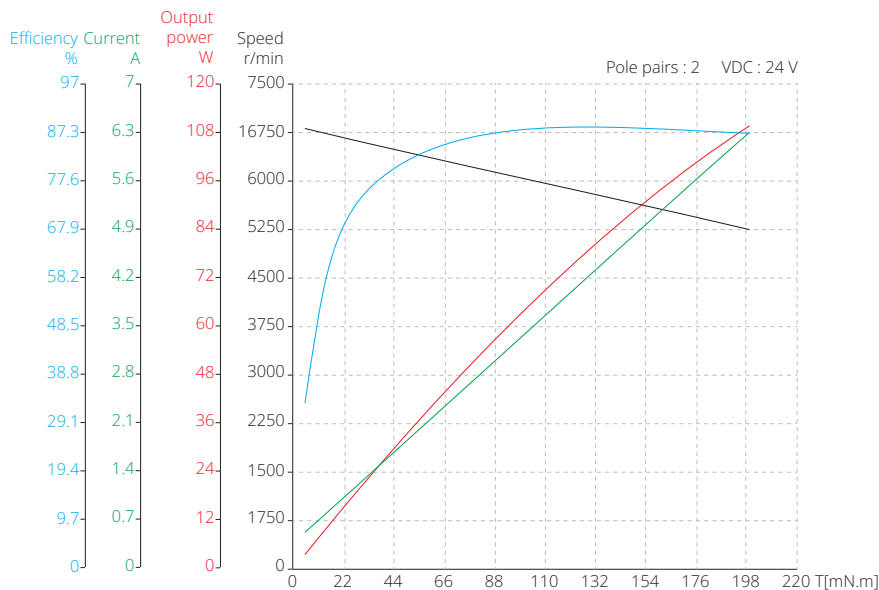
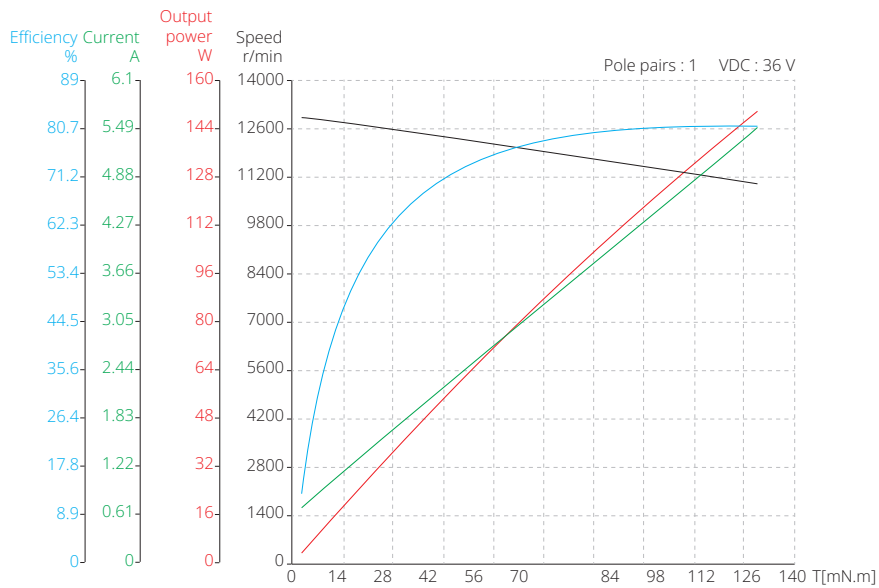

Precision Planetary Gearbox

Precision planetary gearbox

6PGX

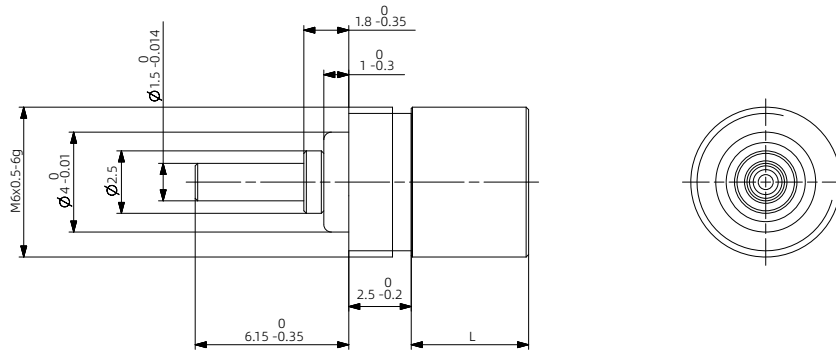

Stage	-	Stage 1	Stage 2	Stage 3
Gear ratio	X : 1	3.9	15	57
Max. backlash	°	1.8	2.0	2.2
Max. continuous output power	W	0.65	0.4	0.2
Max. peak output power	W	0.8	0.5	0.25
Max. continuous input speed	rpm	20000	20000	20000
Max. peak input speed	rpm	25000	25000	25000
Max. continuous torque	N·m	0.002	0.005	0.01
Max. peak torque	N·m	0.005	0.01	0.02
Max. efficiency	%	88	77	68
Weight	g	1.6	2	2.4
Gearbox length L	mm	4.7	7.2	9.7

8PGX

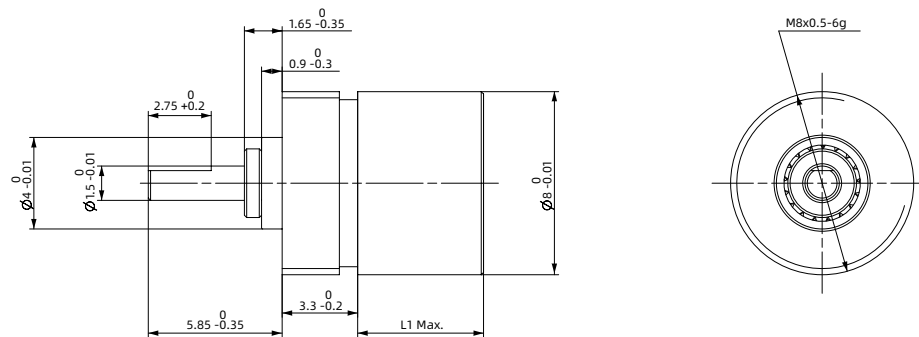

Stage	-	Stage 1	Stage 2	Stage 3
Gear ratio	X : 1	4	16	64
Max. backlash	°	1.8	2.0	2.2
Max. continuous output power	W	0.84	0.52	0.4
Max. peak output power	W	1.05	0.65	0.5
Max. continuous input speed	rpm	14000	14000	14000
Max. peak input speed	rpm	20000	20000	20000
Max. continuous torque	N·m	0.01	0.02	0.06
Max. peak torque	N·m	0.015	0.03	0.09
Max. efficiency	%	90	81	72
Weight	g	2.6	3.2	3.8
Gearbox length L	mm	5.5	8.1	10.7

Precision Planetary Gearbox

● 10PGX

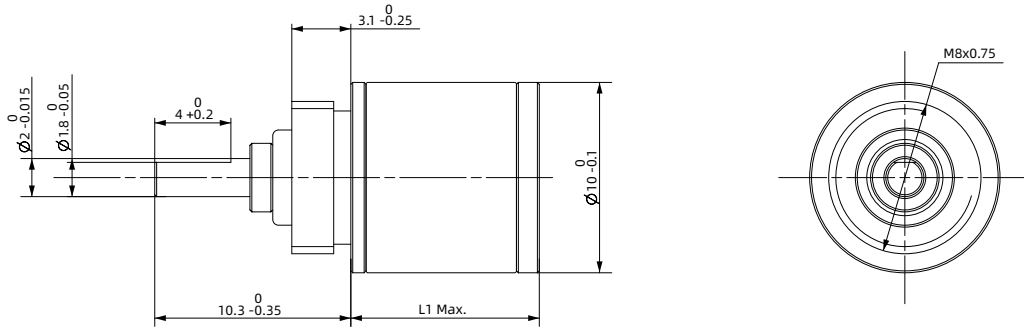

Stage	-	Stage 1	Stage 2	Stage 3	Stage 4
Gear ratio	X : 1	4.25	18	77	326
Max. backlash	°	1.5	1.8	2.0	2.2
Max. continuous output power	W	1.6	1.2	1.0	0.4
Max. peak output power	W	2	1.5	1.3	0.5
Max. continuous input speed	rpm	14000	14000	14000	14000
Max. peak input speed	rpm	18000	18000	18000	18000
Max. continuous torque	N·m	0.01	0.03	0.10	0.15
Max. peak torque	N·m	0.02	0.05	0.15	0.2
Max. efficiency	%	90	81	73	65
Weight	g	6.8	7.3	7.8	8.3
Gearbox length L	mm	10.1	13.6	17.1	20.6

● 12PGX

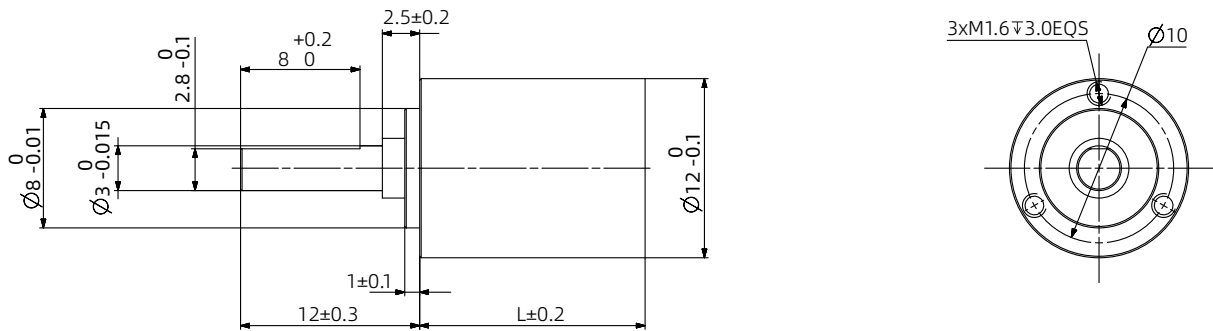

Stage	-	Stage 1	Stage 2	Stage 3	Stage 4
Gear ratio	X : 1	4.3	18.4	79	337
Max. backlash	°	1.2	1.5	1.8	2.1
Max. continuous output power	W	2.0	1	0.5	0.25
Max. peak output power	W	2.5	1.25	0.65	0.3
Max. continuous input speed	rpm	16000	16000	16000	16000
Max. peak input speed	rpm	20000	20000	20000	20000
Max. continuous torque	N·m	0.08	0.11	0.14	0.17
Max. peak torque	N·m	0.1	0.14	0.18	0.21
Max. efficiency	%	90	80	75	65
Weight	g	9	12	15	18
Gearbox length L	mm	11.3	15.1	18.9	22.7

Precision Planetary Gearbox

● 14PGX

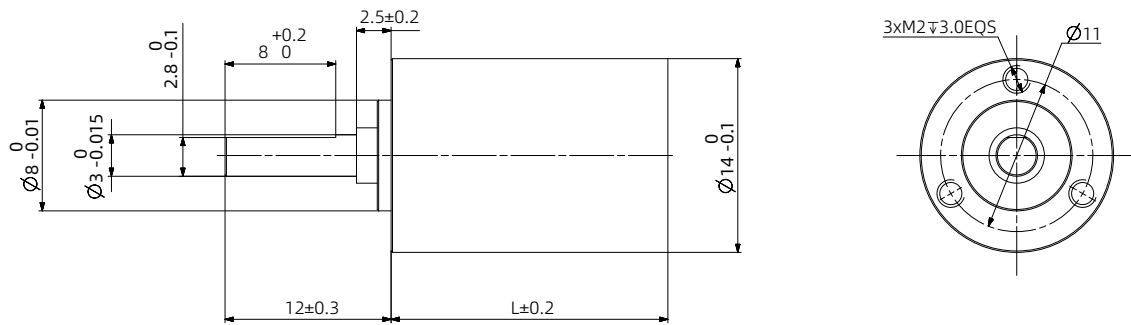

Stage	-	Stage 1	Stage 2	Stage 3	Stage 4
Gear ratio	X : 1	4.3	18.4	79	337
Max. backlash	°	1.1	1.3	1.45	1.7
Max. continuous output power	W	4.0	2.0	1.0	0.4
Max. peak output power	W	5.0	2.5	1.25	0.5
Max. continuous input speed	rpm	14000	16000	16000	16000
Max. peak input speed	rpm	18000	20000	20000	20000
Max. continuous torque	N·m	0.16	0.2	0.25	0.3
Max. peak torque	N·m	0.2	0.25	0.31	0.38
Max. efficiency	%	90	80	75	65
Weight	g	11	15	19	23
Gearbox length L	mm	11.8	16.1	20.4	24.7

● 16PGX

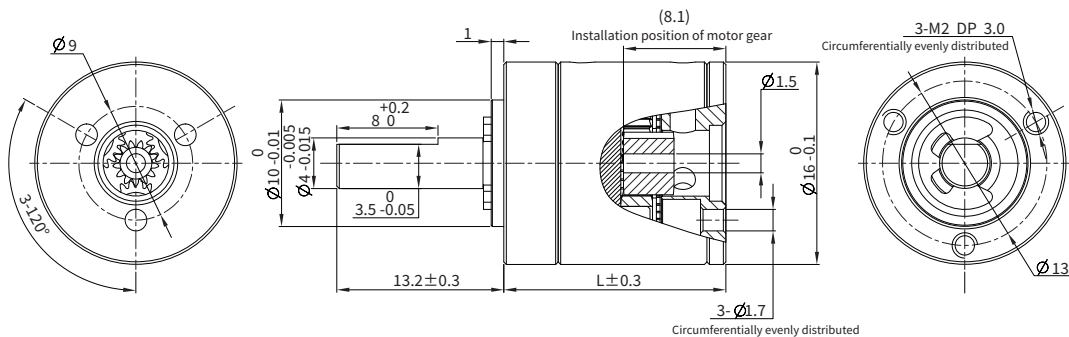

Stage	-	Stage 1	Stage 2	Stage 3	Stage 4
Gear ratio	X : 1	3.9, 5.3	16, 21, 28	62, 83, 111, 150	243, 326, 439, 590, 794
Max. backlash	°	1.0	1.2	1.3	1.4
Max. continuous output power	W	6.5	3.2	1.6	0.6
Max. peak output power	W	8.0	4.0	2.0	0.75
Max. continuous input speed	rpm	12000	14000	14000	14000
Max. peak input speed	rpm	15000	18000	18000	18000
Max. continuous torque	N·m	0.2	0.25	0.35	0.45
Max. peak torque	N·m	0.25	0.35	0.45	0.55
Max. efficiency	%	90	80	75	65
Weight	g	25	31	37	42
Gearbox length L	mm	18.7	25.5	30.2	42

Precision Planetary Gearbox

● 22PGX

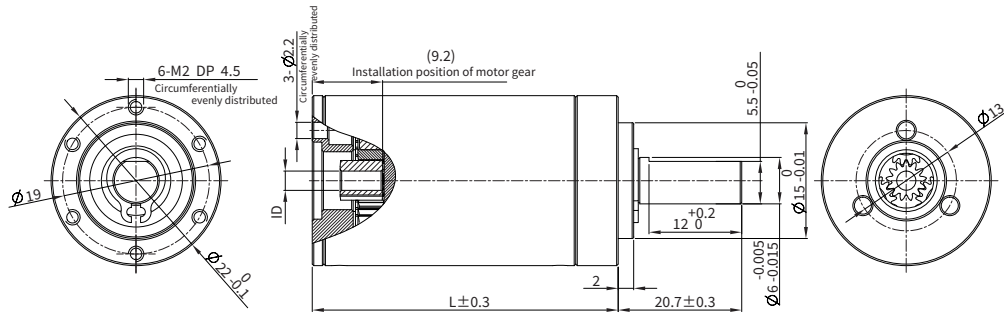

Stage	-	Stage 1	Stage 2	Stage 3	Stage 4
Gear ratio	X : 1	3.9, 5.3	16, 21, 28	62, 83, 111, 150	243, 326, 439, 590, 794
Max. backlash	°	0.85	1.05	1.2	1.35
Max. continuous output power	W	24	12	6.0	1.6
Max. peak output power	W	30	15	7.5	2.0
Max. continuous input speed	rpm	8000	10000	10000	10000
Max. peak input speed	rpm	10000	12500	12500	12500
Max. continuous torque	N·m	0.5	0.7	1.2	1.5
Max. peak torque	N·m	0.6	0.9	1.5	1.9
Max. efficiency	%	90	81	74	66
Weight	g	59	83	97	112
Gearbox length L	mm	22.3	33	39.6	46.3

● 28PGX

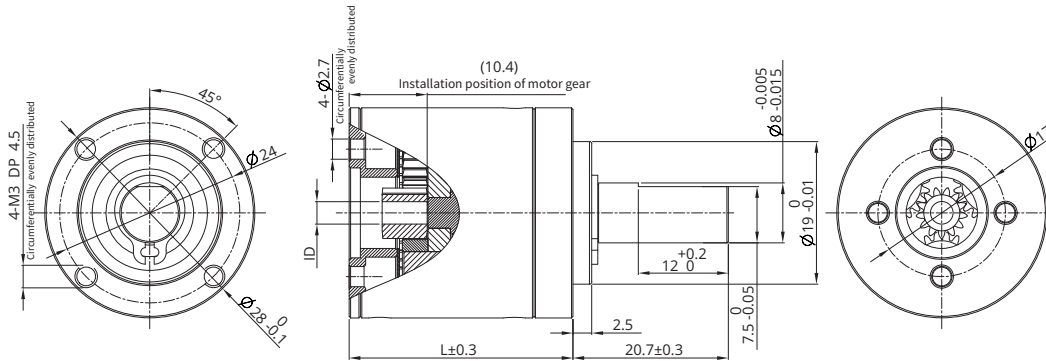

Stage	-	Stage 1	Stage 2	Stage 3	Stage 4
Gear ratio	X : 1	3.9, 5.3	16, 21, 28	62, 83, 111, 150	243, 326, 439, 590, 794
Max. backlash	°	0.5	0.6	0.7	0.75
Max. continuous output power	W	100	50	25	8.0
Max. peak output power	W	125	62	31	10
Max. continuous input speed	rpm	6000	7000	7000	7000
Max. peak input speed	rpm	7500	8750	8750	8750
Max. continuous torque	N·m	1.25	2.9	5.0	5.0
Max. peak torque	N·m	1.6	3.6	6.3	6.3
Max. efficiency	%	90	81	72	65
Weight	g	103	150	174	198
Gearbox length L	mm	24.2	36.9	43.5	50.2

Precision Planetary Gearbox

● 36PGX

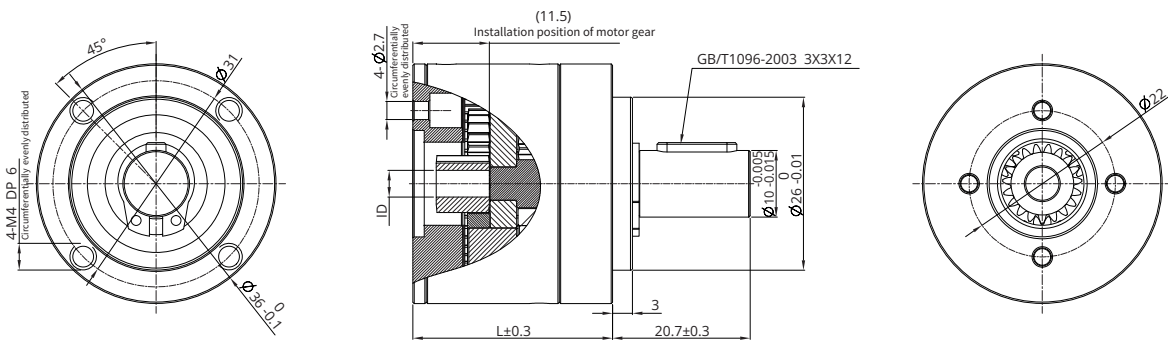

Stage	-	Stage 1	Stage 2	Stage 3	Stage 4
Gear ratio	X : 1	3.9, 5.3	16, 21, 28	62, 83, 111, 150	243, 326, 439, 590, 794
Max. backlash	°	0.5	0.6	0.7	0.8
Max. continuous output power	W	185	90	45	15
Max. peak output power	W	230	115	60	19
Max. continuous input speed	rpm	6000	6000	6000	6000
Max. peak input speed	rpm	7500	7500	7500	7500
Max. continuous torque	N·m	2.3	5.4	9.3	9.3
Max. peak torque	N·m	2.9	6.8	11.6	11.6
Max. efficiency	%	90	80	72	65
Weight	g	156	238	277	315
Gearbox length L	mm	30	44.7	51.3	58

● 42PGX

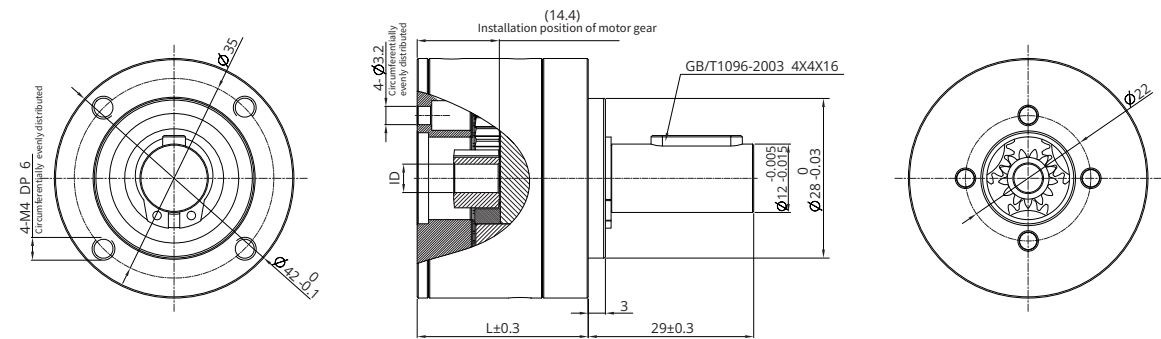

Stage	-	Stage 1	Stage 2	Stage 3	Stage 4
Gear ratio	X : 1	3.9, 5.3	16, 21, 28	62, 83, 111, 150	243, 326, 439, 590, 794
Max. backlash	°	0.3	0.4	0.5	0.6
Max. continuous output power	W	480	200	85	20
Max. peak output power	W	600	250	106	25
Max. continuous input speed	rpm	6000	6000	6000	6000
Max. peak input speed	rpm	7500	7500	7500	7500
Max. continuous torque	N·m	3.0	7.5	15	15
Max. peak torque	N·m	4.5	11.3	22.5	22.5
Max. efficiency	%	90	81	72	64
Weight	g	252	405	476	544
Gearbox length L	mm	36.1	54.9	63.6	72.4



ENG Web

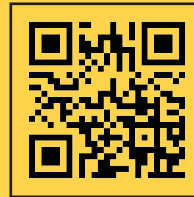

Partners Web

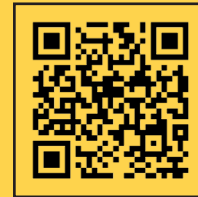

YouTube



HEADQUARTERS

Jiangsu DINGS' Intelligent Control Technology Co., Ltd.

No. 2850 Luheng Road, Changzhou Economic Development Zone, Jiangsu Province, China

Tel : +86-519-85177826

Fax : +86-519-85177807

E-mail : info@dingsmotion.com

www.dingsmotion.com

GLOBAL MANUFACTURING LOCATION

DINGS' Intelligent Control Technology (Thailand) Co., Ltd.

42/29 Moo 4, Uthai Subdistrict, Uthai District, Phra Nakhon Si Ayutthaya 13210, Thailand

Tel : +66 64-505-9951

SUBSIDIARIES

DINGS' Motion USA

355 Cochrane Circle Morgan Hill,
CA 95037

+1-408-612-4970

sales@dingsmotionusa.com

dingsmotionusa.com

DINGS' Motion Europe

4 Avenue du Grand Trémoutier
44120 Vertou, France

+33-(0)6-41-37-80-07

sebastien@dingsmotion.com

fr.dingsmotion.com

DINGS' Korea Co., Ltd.

C-702, 158 Haneulmaeul-ro, Ilsandong-gu,
Goyang-si, Republic of Korea

+82-31-994-0755

daniel@dingsmotion.com

dingsmotion.kr / dkps.co.kr / en.dkps.co.kr

INTERNATIONAL OFFICES

DINGS' Shenzhen Office

Room 1105, Block C, CIMC Industry Park,
Guangming District, Shenzhen, China

info@dingsmotion.com

DINGS' JAPAN

101, 2-27-18, Nishi-kojiya, Ota-ku, Tokyo
144-0034 JAPAN

+81-90-7730-0034

tsukahara@dingsmotion.com

jp.dingsmotion.com

© DINGS'. All rights reserved

No part of this catalog may be reproduced or distributed without prior written consent from DINGS'. Specifications, features, and designs are subject to change without prior notice for product improvement.

DINGS' reserves the right of final interpretation of this catalog and its products.