

# DINGS'

Precision Motion Specialist

## BALL SCREW PRODUCT CATALOG

Jiangsu DINGS' Intelligent Control Technology Co., Ltd.





Founded in 2008, Jiangsu DINGS' Intelligent Control Technology Co., Ltd. is guided by the philosophy, "Quality stems from responsibility, and details determine success."

As a global leader in precision linear motion, DINGS' delivers a comprehensive portfolio of precision stepper, DC and BLDC motors, voice coil motors, lead and ball screw linear actuators, PMSM motors for eco-mobility, and advanced motion controllers — setting new benchmarks in the global motion control market.

## SCALE

300+	Advanced Machining Equipment	
40+	Automated Assembly Lines	
100+	Precision Testing & Analysis Systems	
140+	Patents & Intellectual Properties	

## GROWTH

2008	Company Founded & DINGS' Brand Established
2010	DINGS' Motion USA Established
2016	DINGS' Korea Established
2019	Joined LEILI Group
2021	Changzhou Intelligent Manufacturing Plant Established Listed on China NEEQ Market
2022	Korea R&D Center Established
2023	Listed on Beijing Stock Exchange [Stock Code: 920593] DINGS' Korea Converted to Corporate Entity DINGS' Japan Established
2024	New Headquarters & Plant Established DINGS' Motion Europe Established
2025	Thailand Manufacturing Facility Established

## CERTIFICATIONS



## PRODUCT WARRANTY

Warranty period: 1 year from shipment.  
Free repair is provided for defects in materials or workmanship under normal use.

Warranty does not apply to:

- Warranty expiration or damaged/lost nameplates
- Improper installation or operating conditions
- Unauthorized disassembly or modification
- Repairs conducted outside of official service channels
- Force majeure, including natural disasters

DINGS' is committed to quality, reliability, and responsibility  
— delivering high-performance motion solutions built on precision engineering.

dingsmotion.com

# Content

## BALL SCREW

Technical Overview	4
Operating Instructions & Precautions	10
Ball Screw Dimension Table	13
[FBG · FBR] Flanged Single Nut - type 2	15
[FBG · FBR] Flanged Single Nut - type 1	17
[CBG · CBR] Cylindrical Single Nut	18
[MBG · MBR] Metric Thread Single Nut	19
[KBG · KBR] Square Single Nut	20



## Technical Overview

### 1. Ball Screw Structure

#### ■ Deflector Type

The deflector type uses a deflector or an integrated guide structure installed inside the nut to redirect the ball path and achieve recirculation. Compared with the return tube type, the nut outer diameter can be designed smaller. With a single-circuit design, it provides high load capacity and smooth operation.

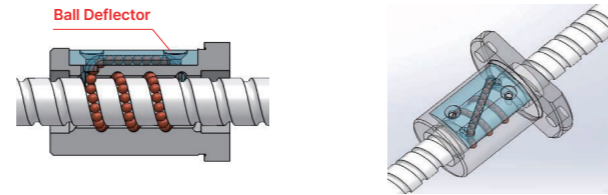

#### ■ Return Tube Type

In the return tube type, the balls travel along the raceway between the screw shaft and the nut while carrying the axial load. They then move to an adjacent raceway through the return tube and re-enter the load zone, forming a continuous circulation path.



#### ■ End Deflector Type

The end deflector type uses an end deflector installed inside the nut to guide the balls into the nut body, allowing them to circulate continuously along raceways in the same direction. Compared with the deflector type, the nut can be designed with a more compact radial dimension, making it particularly suitable for medium lead applications.

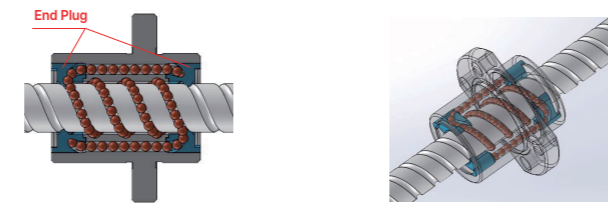

#### ■ End Cap Type

In the end cap type, the balls move along the raceway between the screw shaft and the nut. They are then guided through end caps installed at both ends of the nut and return to the starting point through an internal passage inside the nut body, forming a closed-loop circulation system.

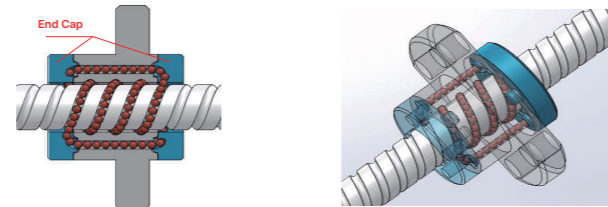

### 2. Production Range of Ball Screws

DINGS' ball screws are available in nominal screw shaft diameters from Ø4 mm to Ø25 mm. The table below shows the reference maximum shaft lengths by accuracy grade. Actual lengths may vary depending on shaft-end configuration, material, and series. For details, please contact our sales engineers.

#### ■ Maximum Overall Length of Precision Ball Screws

Unit: mm

Nominal Dia.	Accuracy Grade			
	C3 (Ground)	C5 (Ground)	C7 (Rolled)	C10 (Rolled)
4	160	170	400	400
6	240	250	600	600
8	330	400	600	600
10	420	450	600	600
12	510	550	600	600
14	600	700	600	600

#### Notes

- For lengths exceeding the maximum production limit, please contact our sales engineers.
- For rolled ball screws, the maximum length includes 25 mm of incomplete thread at each end.

## Technical Overview

### 3. Lead Accuracy of Ball Screws

The lead accuracy of a ball screw refers to the representative deviation and variation of the travel error relative to the effective nut travel or the effective threaded length of the screw shaft. It also includes the variation measured over any 300 mm length of the effective thread and over one revolution ( $2\pi$  rad).

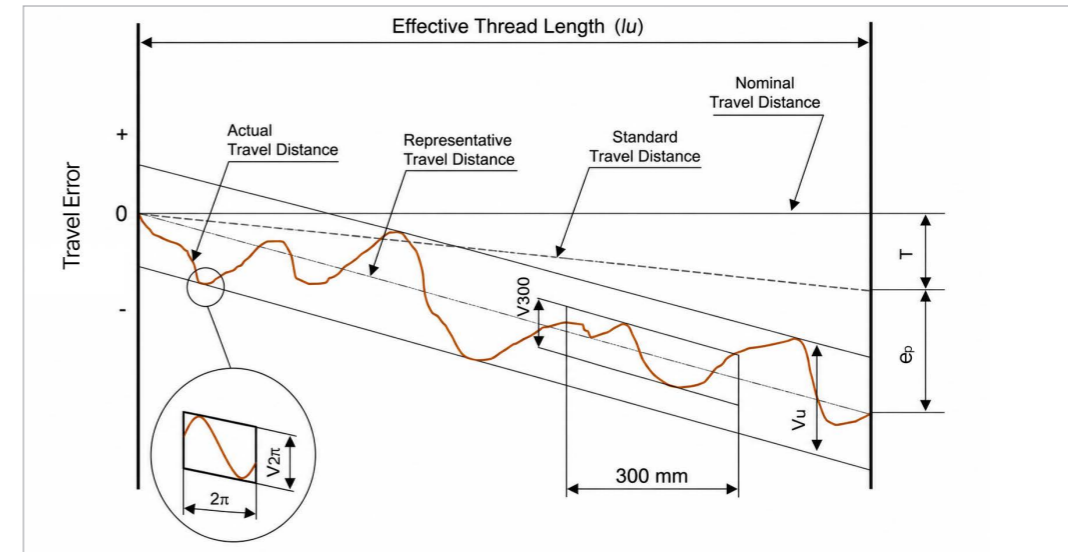

[Travel Error Diagram]

**Nominal Travel Distance:** The axial travel distance of the nut corresponding to any number of revolutions based on the nominal lead.

**Target Reference Travel Value (T):** A corrected lead value that accounts for the effects of temperature rise and load deformation, serving as the target reference for travel distance.

**Standard Travel Distance:** The travel distance produced by the nut when rotating any number of revolutions based on the target reference travel value.

**Actual Travel Distance:** The actual axial travel distance produced by the nut for a given rotation angle of the screw shaft.

**Representative Travel Distance:** A best-fit line reflecting the trend of actual travel distance, derived from actual travel data within the effective travel range or effective thread length of the ball screw using the least squares method or equivalent.

**Representative Travel Error (ep):** The difference between the representative travel distance and the standard travel distance within the effective travel range of the nut or the effective thread length of the screw shaft.

**Variation (Vu):** The maximum variation of actual travel distance between two lines drawn parallel to the representative travel distance line.

**Variation (V300):** The maximum variation of actual travel distance over any selected 300 mm section within the effective thread length.

**Variation (V2pi):** The maximum variation of actual travel distance over any selected one-revolution ( $2\pi$  rad) section within the effective thread length.

#### Allowable Representative Travel Error ( $\pm e_p$ ) and Variation ( $V_u$ )

Unit:  $\mu\text{m}$

Effective Threaded Length (mm)	Accuracy Grade		C3		C5	
	Over	Up to	$\pm e_p$	$V_u$	$\pm e_p$	$V_u$
	-	100	8	8	18	18
	100	200	10	8	20	18
	200	315	12	8	23	18
	315	400	13	10	25	20
	400	500	15	10	27	20
	500	630	16	12	30	23
	630	800	18	13	35	25
	800	1000	21	13	40	27

## Technical Overview

Permissible Variation ( $V_{300}$ ) and ( $V_{2\pi}$ ) per 300 mm and One Revolution for Precision Ball Screws

Unit :  $\mu\text{m}$

Precision Grade	C3		C5	
	$V_{300}$	$V_{2\pi}$	$V_{300}$	$V_{2\pi}$
Permissible Value	8	6	18	8

Variation ( $V_{300}$ ) for C7 and C10 over 300 mm

Unit :  $\mu\text{m}$

Precision Grade	C7	C10
$V_{300}$	52	210

The representative travel error ( $e_p$ ) for C7 and C10 is calculated using the following formula:

$$e_p = \pm \frac{l_u}{300} \times V_{300} \quad l_u : \text{Effective thread length (mm)}$$

### 4. Material, Heat Treatment, and Hardness

The standard material, heat treatment, and hardness of DINGS' ball screws are shown in the table below. Values may vary slightly depending on the series and model; please refer to the specifications provided by DINGS'.

Component	Material	Heat Treatment	Thread Surface Hardness
Screw Shaft	SUJ2 (JIS G 4105)	Induction hardening	HRC 58-62
	S55C (JIS G 4105)	Induction hardening	HRC $\geq 58$
	SUS440C	Quenched and tempered	HRC $\geq 55$
Ball Nut	SCM420H (JIS G 4105)	Carburized and hardened	HRC 58-62
	SUS440C	Quenched and tempered	HRC $\geq 55$

**Note:** S55C material is used for rolled ball screws, while SUJ2 material is used for ground ball screws.

### 5. Axial Clearance and Preload

#### ■ Axial Clearance

In standard single-nut ball screws, a small axial clearance typically exists between the screw shaft and the nut. Under axial loading, this inherent clearance combines with elastic deformation caused by the applied load, resulting in increased backlash. To eliminate backlash, the axial clearance must be set to a negative value — that is, elastic deformation is intentionally induced between the screw shaft and nut in advance through preloading. The combinations of axial clearance and accuracy grades available for DINGS' ball screws are shown in the table below.

The clearance symbols and allowable axial clearance values for DINGS' ball screws are shown in the table below. The combinations of accuracy grade and clearance symbol are also indicated in the table.

Axial Clearance	Z (Preload)	T ( $\leq 0.005$ mm)	S ( $\leq 0.02$ mm)	N ( $\leq 0.05$ mm)
Accuracy Grade				
C3	●	●	●	●
C5		●	●	●
C7			●	●
C10			●	●

## Technical Overview

#### ■ Effect of Preload

Preload is applied to eliminate axial clearance and minimize axial displacement under load, thereby increasing the rigidity of the ball screw.

The graph below shows the elastic displacement curves with and without preload. As illustrated, applying preload reduces axial elastic displacement by approximately half compared to a clearance-type configuration, resulting in significantly improved stiffness.

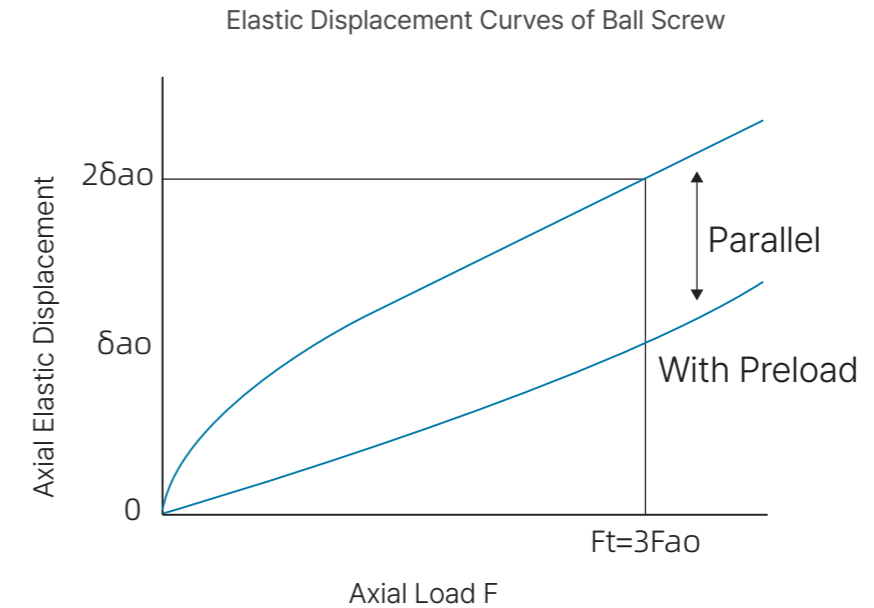

#### ■ Appropriate Preload Amount

The preload amount should be determined based on the required stiffness or allowable backlash. However, applying preload may result in the following effects:

1. Increased dynamic torque
2. Reduced positioning accuracy due to heat generation and temperature rise
3. Shortened service life

Therefore, the preload amount should be set as low as possible while meeting performance requirements.

■ Preload Methods

In ball screw preloading, the double-nut preload method is commonly used, where a shim (spacer) is inserted between two nuts to apply preload force. DINGS' ball screws, however, take full advantage of the structural characteristics of miniature ball screws by adopting an "oversized ball preload" method, in which steel balls with a diameter slightly larger than the clearance between the screw shaft and nut are used to apply preload. This method eliminates axial clearance with a single nut, enabling a more compact design. In addition, "spacer balls" — slightly smaller in diameter than the preload balls — are placed alternately between preload balls in the raceway, effectively preventing degradation of motion performance due to excessive preload.

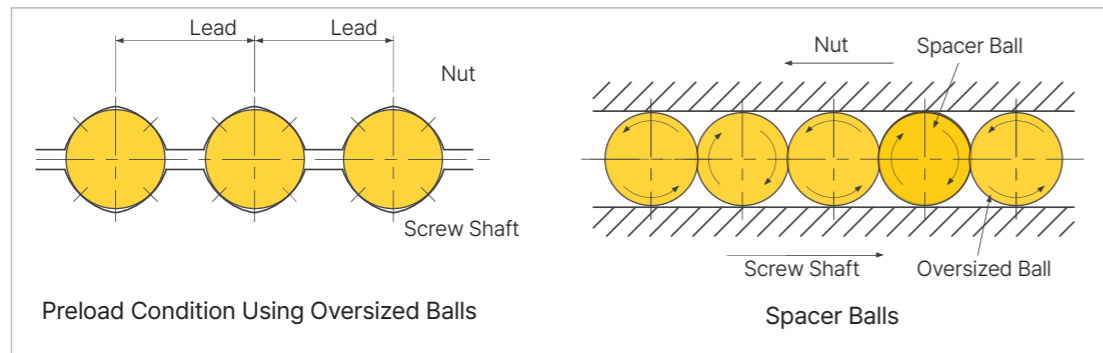

■ Preload Management

Since the preload amount in a ball screw cannot be measured directly, it is common engineering practice to convert it into a preload running torque, which is then measured to indirectly monitor the preload condition. The nominal value of preload running torque is specified in the specification drawing, with the actual value to be agreed upon between the supplier and the customer. To ensure effective management of the preload amount (i.e., zero axial clearance), preload running torque must be measured under strictly consistent conditions. It should be noted that lubrication conditions and operating environments vary across different machines, and the actual measured running torque may deviate accordingly. Furthermore, the starting torque of a ball screw — the torque required to initiate motion — is generally slightly higher than the preload running torque, and this should also be taken into consideration.

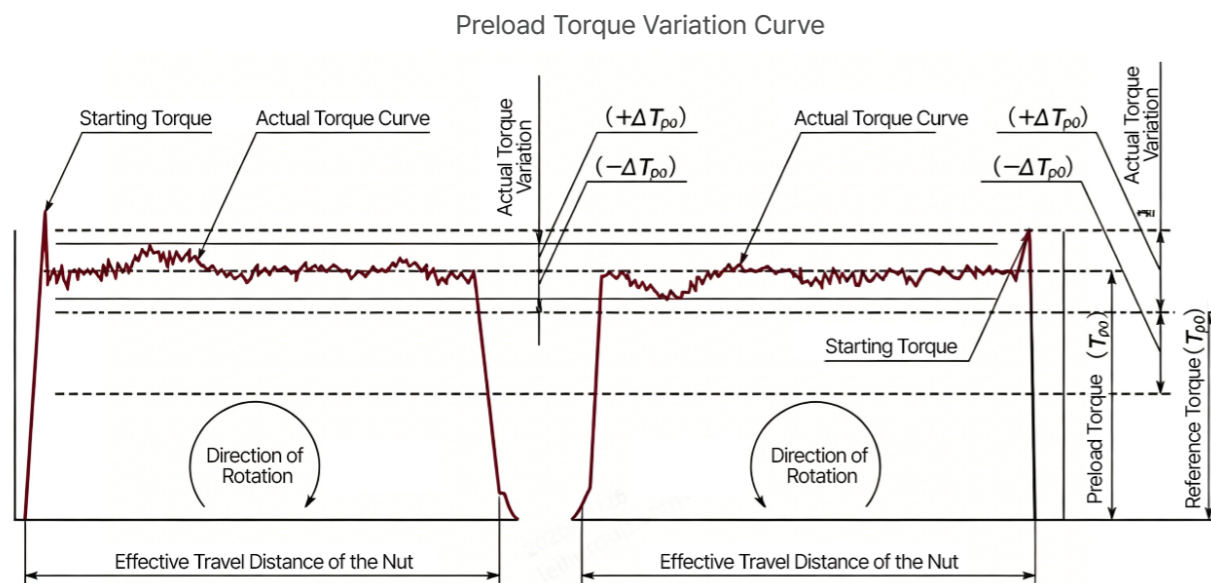

**Note:** The torque variation illustrated in this figure has been intentionally exaggerated for explanatory purposes.

6. Rust Prevention and Lubrication

■ Rust Prevention

DINGS' ball screws are coated with rust-preventive oil for long-term storage. Before use, remove the oil with clean refined kerosene and apply lubricating oil or grease. Grease can be applied prior to shipment upon request; however, long-term storage with grease may cause rust.

**Note:** The rust-preventive oil is for corrosion protection only and provides no lubrication. Using the ball screw without removing this oil may reduce service life and cause increased torque or abnormal heat generation.

■ Lubrication

Lubrication is essential when using ball screws. Insufficient lubrication may cause increased torque and shortened service life. Proper lubrication suppresses temperature rise due to friction, loss of mechanical efficiency, and accuracy degradation caused by wear. Ball screws can be lubricated with grease or oil. Grease lubrication: Lithium soap-based grease is generally recommended. Oil lubrication: ISO VG 32–68 (turbine oil) is recommended.

Selecting the appropriate lubricant according to the application is particularly important. For miniature ball screws, grease churning resistance may increase torque. DINGS' provides proprietary greases optimized for ball screw performance: MSG No.1 (NLGI No.1) for low-speed positioning applications requiring smooth motion, and MSG No.2 (NLGI No.2) for high-speed and general-purpose applications.

Recommended Lubricants

Lubricant Type	Category	Product Name
Grease	Lithium-based grease	AFG Grease
Lubricating Oil	Slideway oil or turbine oil	Super Multi 68

■ Inspection and Replenishment

When using grease lubrication, inspections should be conducted every 2–3 months; when using oil lubrication, inspections should be conducted weekly. During inspection, check the lubricant quantity and contamination, and replenish as necessary. When adding new grease, remove old and discolored grease as thoroughly as possible.

Lubrication Method	Inspection Interval	Inspection Items	Replenishment / Replacement Interval
Automatic Intermittent Lubrication	Weekly	Oil quantity, contamination	Replenish appropriately at each inspection based on reservoir capacity
Grease	Initial operation: 2–3 months	Contamination, chips, foreign matter	Typically replenished once per year; adjust based on inspection results and remove discolored old grease
Oil Bath	Before daily operation	Oil level	Adjust appropriately according to consumption

## Technical Overview

### 7. Support-side Shaft End Machining Type

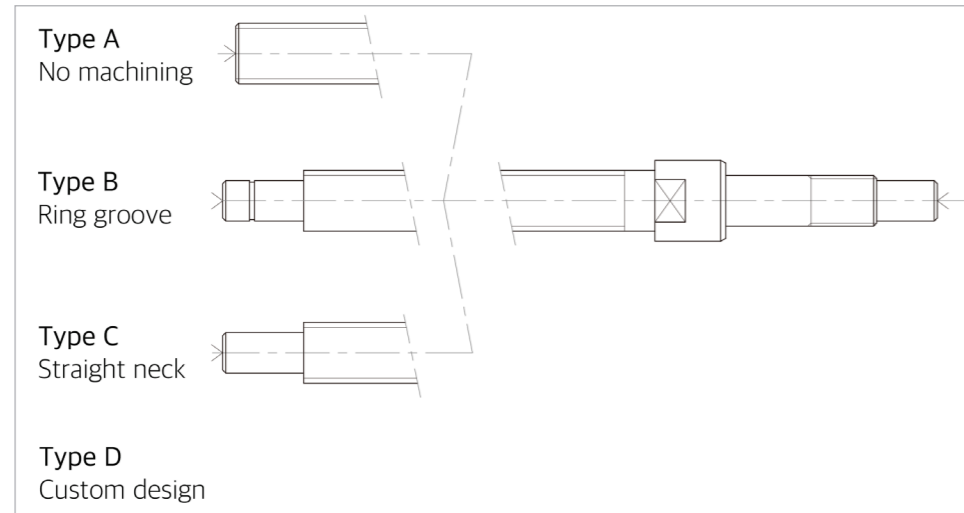

### 8. Nut Flange Orientation

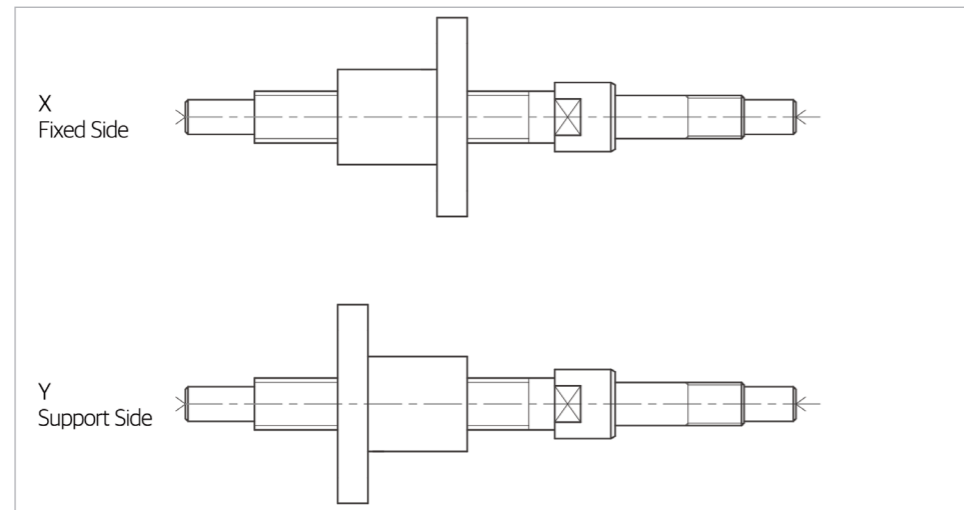

## Operating Instructions & Precautions

### Instructions for Use

During storage, keep the product in its original packaging. Do not open or damage the internal packaging, as this may allow foreign matter to enter or cause corrosion, resulting in degraded performance.

#### Operating Instructions

1. Do not disassemble the product. Disassembly may cause foreign matter intrusion, loss of accuracy, or accidents.
2. Do not attempt reassembly. Incorrect reassembly may damage the ball screw. Please return the product to DINGS' for paid repair and reassembly.
3. Handle with care. The screw shaft or nut may detach due to their own weight, posing a risk of injury. If detachment occurs, circulation components may be damaged, affecting performance. In such cases, we recommend sending the product to DINGS' for professional inspection and paid repair.
4. Avoid dropping the product. Dropping may cause scratches or damage to circulation components, shaft outer diameter, or steel balls, potentially resulting in impaired operation such as rough or uneven motion.

### Precautions for Use



#### Warning – Risk of Personal Injury

Failure to follow these warnings may result in serious injury or death.

#### Disassembly Prohibited

Do not disassemble the ball screw shaft, ball nut, or any internal components. Disassembly may cause the internal balls or circulation components to unexpectedly fall out or be ejected. This may result in serious personal injury, contamination, loss of functionality, or damage to the circulation components.

#### Ball Nut Removal Prohibited

Do not remove the ball nut from the ball screw shaft. Removing the nut may cause the balls to fall out or be ejected, creating a potential hazard that may result in serious personal injury or product damage. If disassembly is required, please contact DINGS' for the proper procedure.

#### Overtravel

Excessive movement of the ball nut (overtravel) may cause ball dropout, damage to circulation components, or indentation of the ball raceway, resulting in poor operation. Continued use under such conditions may lead to premature wear or component failure. Overtravel must be avoided.

If overtravel occurs, immediately stop operation and contact DINGS' for inspection (paid service).

#### Abnormal Operation

If abnormal noise, vibration, increased resistance, jamming, or irregular motion is observed during operation, stop the system immediately. Continued operation under such conditions may cause sudden failure, loss of control, or unsafe motion, which may lead to serious injury.

#### Ball or Rolling Element Dropout

If any ball or rolling element falls out of the ball screw, stop using the product immediately. Do not operate the product under this condition. Contact DINGS' for inspection and repair.



#### Warning – Equipment Damage / Reduced Service Life

Failure to follow these precautions may result in product damage, malfunction, or reduced service life.

#### Handling and Impact

The ball screw and ball nut are heavy and precision-machined components. Avoid dropping the product or applying impact loads. Dropping or impact may cause serious personal injury and internal damage that may not be visible externally.

## Operating Instructions & Precautions

### ■ Dust Protection

The ball screw can be used in contaminated environments if appropriate protection measures are applied. Install protective covers or equivalent measures to prevent foreign matter or chips from entering the ball screw. For information on improving contamination resistance in your operating environment, please contact the DINGS' sales team.

### ■ Lubrication

Check the lubrication condition before use. Insufficient lubrication may cause the ball screw to lose functionality in a short time. Rust-preventive oil is not a lubricant. Before operation, remove the rust-preventive oil with refined kerosene or an equivalent cleaner, then apply lubricant (grease or oil). Under normal operating conditions, inspect the grease every 2–3 months. If the grease becomes contaminated during operation, remove the old grease and apply new grease.

### ■ Allowable Speed and Axial Load

Allowable axial load and rotational speed vary depending on the size, material, accuracy grade, mounting method, and operating conditions of the ball screw. Exceeding the allowable limits may result in abnormal wear, excessive heat generation, or premature failure. It is recommended to consult DINGS' regarding the operating conditions during the design stage.

### ■ Operating Temperature

The maximum operating temperature is typically below 80 °C. Operation above this temperature may result in the following:

1. Degradation of ball circulation performance
2. Damage or failure of circulation components
3. Reduction in hardness of heat-treated parts

For applications requiring operation above 80 °C, please contact a DINGS' sales engineer in advance.

### ■ Eccentric Load

The ball screw is designed to generate axial thrust and cannot withstand radial loads or moment loads. If radial, bending, or moment loads are applied to the ball nut, the load acting on the balls becomes uneven, which may significantly reduce service life. Eccentricity between the bearing support and the nut housing during installation may also result in eccentric loading. Proper alignment must be ensured during installation.

### ■ Reciprocating (Short Stroke) Motion

When repeated forward and reverse motion occurs within a short stroke range, dynamic torque may increase due to ball compression and elastic deformation. This may lead to increased friction, heat generation, and accelerated wear. To mitigate these effects, it is recommended to periodically operate the ball screw over the full stroke range.

### Notice

To prevent ball nut overtravel or disengagement from the threaded section, O-rings may be installed during transportation or handling.

Be sure to remove the O-rings before operating the product.

## BALL SCREW SERIES OVERVIEW



## Ball Screw Dimension Table

Nominal Diameter		Lead		Lead Code	Outer Diameter (Reference)		Root Diameter (Reference)		Left-hand Thread Option		Standard Stock	
Imperial (inch)	Metric (mm)	Imperial (inch)	Metric (mm)		Imperial (inch)	Metric (mm)	Imperial (inch)	Metric (mm)	C5	C7	Ground <sup>1</sup> (mm)	Rolled <sup>2</sup> (mm)
0.157	4	0.039	1	0401	0.157	4	0.13	3.3	YES	-	55R80 65R80 72R90 100R120	400max
		0.079	2	0402	0.157	4	0.13	3.3	YES	-	35R60 50R70 95R120	400max
0.236	6	0.039	1	0601	0.236	6	0.209	5.3	YES	-	50R80 70R100 90R120 110R140 150R180	400max
		0.079	2	0602	0.236	6	0.193	4.9	YES	-	90R120 130R160 150R180	400max
		0.236	6	0606	0.236	6	0.197	5	YES	-	50R80 70R100 120R150 130R160 160R190 220R250	400max
		0.394	10	0610	0.236	6	0.197	5	YES	-	160R190	400max

### 1. Effective stroke / screw length notation

Example: 55R80 indicates an effective stroke of 55 mm and a total screw length of 80 mm.

### 2. Rolled C7 shaft-end limitation

For rolled C7 ball screws, the shaft-end diameter must not exceed the root diameter of the screw.

### Notes

For lengths exceeding the maximum production limit, please contact our sales engineers.

## Ball Screw Dimension Table

Nominal Diameter		Lead		Lead Code	Outer Diameter (Reference)		Root Diameter (Reference)		Left-hand Thread Option		Standard Stock	
Imperial (inch)	Metric (mm)	Imperial (inch)	Metric (mm)		Imperial (inch)	Metric (mm)	Imperial (inch)	Metric (mm)	C5	C7	Ground <sup>1</sup> (mm)	Rolled <sup>2</sup> (mm)
0.315	8	0.039	1	0801	0.315	8	0.287	7.3	YES	-	90R120 93R140 130R160 210R240	600max
		0.079	2	0802	0.315	8	0.28	7.1	YES	-	90R120 130R160 140R170 210R240 270R305	600max
		0.197	5	0805	0.315	8	0.264	6.7	YES	-	90R120 110R140 140R170 170R200 210R240 400R450	600max
		0.315	8	0808	0.315	8	0.264	6.7	YES	-	90R120 140R170 160R190 217R247 260R305 315R345	600max
		0.394	10	0810	0.315	8	0.264	6.7	YES	-	140R170 200R240 200R300 210R240 275R305 320R350	600max
0.394	10	0.472	12	0812	0.315	8	0.264	6.7	YES	-	100R130 160R190	600max
		0.079	2	1002	0.394	10	0.354	9	YES	-	110R130 110R140 210R240	600max
0.472	12	0.079	2	1202	0.472	12	0.437	11.1	YES	-	140R180 150R180 190R220	600max
		0.079	5	1205	0.472	12	0.402	10.2	YES	-	140R180 150R180 190R220 300R350	600max

### 1. Effective stroke / screw length notation

Example: 55R80 indicates an effective stroke of 55 mm and a total screw length of 80 mm.

### 2. Rolled C7 shaft-end limitation

For rolled C7 ball screws, the shaft-end diameter must not exceed the root diameter of the screw.

### Notes

For lengths exceeding the maximum production limit, please contact our sales engineers.

## [FBG · FBR] Flanged Single Nut - type 2

## [FBG · FBR] Flanged Single Nut - type 2

### Part Number Construction

Example	<b>FBG</b>	<b>06</b>	<b>01</b>	<b>D</b>	<b>X</b>	<b>- 60</b>	<b>R</b>	<b>90</b>	<b>C3</b>	<b>Z</b>	<b>- 001</b>
	①	②	③	④	⑤	⑥	⑦	⑧	⑨	⑩	⑪

#### ① Series

FBG = Flanged single nut (ground)  
FBR = Flanged single nut (rolled)

#### ② Screw Diameter (mm)

06 = 6mm

#### ③ Lead (mm)

01 = Standard ball lead, 1 mm  
01K = Non-standard ball lead, 1 mm

#### ④ Ball Return Type

D = Deflector Type  
S = End Deflector type  
T = Return Tube type  
C = End-cap type

#### ⑤ Custom Option (Non-standard)

#### ⑥ Threaded Section Length (mm)

Decimal point is indicated by “\_”

#### ⑦ Thread Direction

R = Right-hand  
L = Left-hand  
LR = Right- & Left-hand

#### ⑧ Total Screw Length (mm)

Decimal point is indicated by “\_”

#### ⑨ Accuracy Grade

C3 = JIS Standard C3  
C5 = JIS Standard C5  
C7 = JIS Standard C7  
C10 = JIS Standard C10

#### ⑩ Axial Clearance

Z = Preload  
T = ≤ 0.005 mm  
S = ≤ 0.02 mm  
N = ≤ 0.05 mm

#### ⑪ Custom Serial Number

### Mechanical Dimension

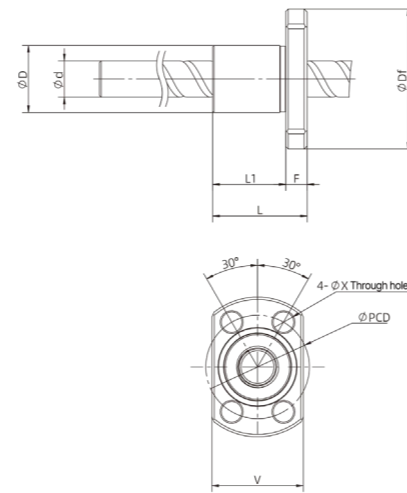

Nut Type	2	2	2	2	2	2	2	2	2	2	2	2	2	2	2	2	2	2	2
Screw Diameter D (mm / inch)	4 (0.16)	4 (0.16)	4 (0.16)	6 (0.24)	6 (0.24)	6 (0.24)	6 (0.24)	6 (0.24)	6 (0.24)	6 (0.24)	8 (0.31)	8 (0.31)	8 (0.31)	8 (0.31)	8 (0.31)	10 (0.394)	10 (0.394)	12 (0.47)	12 (0.47)
Lead (mm / inch)	1 (0.04)	1 (0.04)	2 (0.08)	1 (0.04)	1 (0.04)	1 (0.04)	2 (0.08)	2 (0.08)	2 (0.08)	6 (0.24)	1 (0.04)	1 (0.04)	2 (0.08)	2 (0.08)	5 (0.2)	2 (0.08)	2 (0.08)	2 (0.08)	2 (0.08)
Nut Diameter D (mm / inch)	9 (0.354)	10 (0.394)	11 (0.433)	11 (0.433)	12 (0.472)	12 (0.472)	15 (0.591)	12 (0.472)	15 (0.591)	12 (0.472)	13 (0.511)	14 (0.551)	15 (0.591)	14 (0.551)	18 (0.709)	17 (0.669)	18 (0.709)	19 (0.748)	20 (0.787)
Nut Overall Length L (mm / inch)	13 (0.511)	12 (0.472)	19 (0.748)	15.5 (0.610)	15 (0.591)	15 (0.591)	17 (0.669)	16 (0.63)	17 (0.669)	22 (0.866)	16 (0.63)	16 (0.63)	18 (0.709)	16 (0.63)	28 (1.102)	19 (0.748)	28 (1.102)	19 (0.748)	28 (1.102)
Mounting Length L1 (mm / inch)	10 (0.394)	9 (0.354)	15 (0.591)	12 (0.472)	11.5 (0.453)	11.5 (0.453)	13 (0.512)	12.5 (0.492)	13 (0.512)	18 (0.709)	12 (0.472)	12 (0.472)	14 (0.551)	12 (0.472)	24 (0.945)	14 (0.551)	23 (0.906)	14 (0.551)	23 (0.906)
Flange Diameter Df (mm / inch)	19 (0.748)	20 (0.787)	23 (0.906)	23 (0.906)	24 (0.945)	24.5 (0.965)	29 (1.142)	24 (0.945)	29 (1.142)	24 (0.945)	26 (1.024)	27 (1.063)	28 (1.102)	27 (1.063)	31 (1.22)	33 (1.299)	34.5 (1.358)	36 (1.417)	37 (1.457)
Flange Thickness F (mm / inch)	3 (0.118)	3 (0.118)	4 (0.157)	3.5 (0.138)	3.5 (0.138)	3.5 (0.138)	4 (0.157)	3.5 (0.138)	4 (0.157)	4 (0.157)	4 (0.157)	4 (0.157)	4 (0.157)	4 (0.157)	4 (0.157)	5 (0.197)	5 (0.197)	5 (0.197)	5 (0.197)
Mounting Hole Diameter X (mm / inch)	2.9 (0.114)	2.9 (0.114)	3.4 (0.134)	3.4 (0.134)	3.4 (0.134)	3.4 (0.134)	3.4 (0.134)	3.4 (0.134)	3.4 (0.134)	3.4 (0.134)	3.4 (0.134)	3.4 (0.134)	3.4 (0.134)	3.4 (0.134)	3.4 (0.134)	4.5 (0.177)	4.5 (0.177)	4.5 (0.177)	4.5 (0.177)
Bolt Circle Diameter (PCD) (mm / inch)	14 (0.551)	15 (0.591)	17 (0.669)	17 (0.669)	18 (0.709)	20 (0.787)	22 (0.866)	18 (0.709)	23 (0.906)	18 (0.709)	20 (0.787)	21 (0.827)	22 (0.866)	21 (0.827)	25 (0.984)	26 (1.024)	27 (1.063)	28 (1.102)	29 (1.142)
Nut Flat Width V (mm / inch)	13 (0.512)	14 (0.551)	15 (0.591)	15 (0.591)	16 (0.63)	16 (0.63)	19 (0.748)	16 (0.63)	19 (0.748)	16 (0.63)	17 (0.669)	18 (0.709)	19 (0.748)	18 (0.709)	20 (0.787)	22 (0.866)	22 (0.866)	23 (0.906)	24 (0.945)
Basic Dynamic Load Rating Ca (N)	560	560	420	680	680	680	880	880	880	870	780	780	1300	1300	1850	1450	1450	1600	1600
Basic Static Load Rating Coa (N)	790	790	570	1200	1200	1200	1500	1500	1500	1450	1650	1650	2300	2300	3000	3000	3000	3700	3700

## [FBG · FBR] Flanged Single Nut - type 1

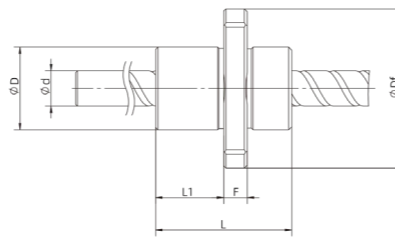
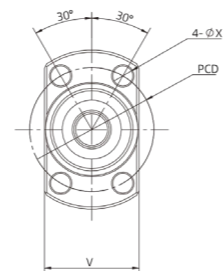
Part Number Construction											Mechanical Dimension	
Example	FBG	06	01	D	X - 60	R	90	C3	Z - 001			
	①	②	③	④	⑤	⑥	⑦	⑧	⑨	⑩	⑪	
① Series	FBG = Flanged single nut (ground) FBR = Flanged single nut (rolled)					⑦ Thread Direction R = Right-hand L = Left-hand LR = Right- & Left-hand						
② Screw Diameter (mm)	06 = 6mm					⑧ Total Screw Length (mm) Decimal point is indicated by "_"						
③ Lead (mm)	01 = Standard ball lead, 1 mm 01K = Non-standard ball lead, 1 mm					⑨ Accuracy Grade C3 = JIS Standard C3 C5 = JIS Standard C5 C7 = JIS Standard C7 C10 = JIS Standard C10						
④ Ball Return Type	D = Deflector Type S = End Deflector type T = Return Tube type C = End-cap type					⑩ Axial Clearance Z = Preload T = ≤ 0.005 mm S = ≤ 0.02 mm N = ≤ 0.05 mm						
⑤ Custom Option (Non-standard)						⑪ Custom Serial Number						
⑥ Threaded Section Length (mm)	Decimal point is indicated by "_"											

Nut Type	1	1	1	1	1	1
Screw Diameter D (mm / inch)	6 (0.24)	6 (0.24)	8 (0.31)	8 (0.31)	8 (0.31)	12 (0.472)
Lead (mm / inch)	6 (0.24)	10 (0.39)	8 (0.31)	10 (0.39)	12 (0.47)	5 (0.197)
Nut Diameter D (mm / inch)	14 (0.551)	14 (0.551)	18 (0.709)	18 (0.709)	18 (0.709)	24 (0.945)
Nut Overall Length L (mm / inch)	17.2 (0.677)	23 (0.906)	21.5 (0.846)	24 (0.945)	28 (1.102)	30 (1.181)
Mounting Length L1 (mm / inch)	8 (0.315)	11.5 (0.453)	11.5 (0.453)	13 (0.512)	18 (0.709)	15 (0.591)
Flange Diameter Df (mm / inch)	27 (1.063)	27 (1.063)	31 (1.22)	31 (1.22)	31 (1.22)	40 (1.575)
Flange Thickness F (mm / inch)	4 (0.157)	4 (0.157)	4 (0.157)	4 (0.157)	4 (0.157)	10 (0.39)
Mounting Hole Diameter X (mm / inch)	3.4 (0.134)	3.4 (0.134)	3.4 (0.134)	3.4 (0.134)	3.4 (0.134)	4.5 (0.177)
Bolt Circle Diameter (PCD) (mm / inch)	21 (0.827)	21 (0.827)	25 (0.984)	25 (0.984)	25 (0.984)	32 (1.260)
Nut Flat Width V (mm / inch)	16 (0.63)	16 (0.63)	20 (0.787)	20 (0.787)	20 (0.787)	30 (1.181)
Basic Dynamic Load Rating Ca (N)	870	950	2200	2200	2200	4100
Basic Static Load Rating Coa (N)	1450	1600	3800	3900	4000	7400

## [CBG · CBR] Cylindrical Single Nut

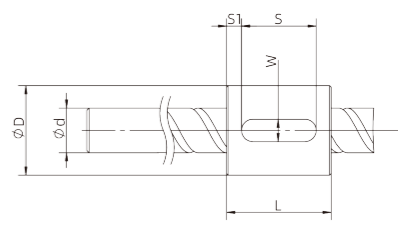
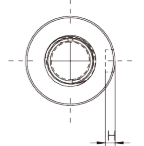
Part Number Construction											Mechanical Dimension	
Example	CBG	06	01	D	X - 60	R	90	C3	Z - 001			
	①	②	③	④	⑤	⑥	⑦	⑧	⑨	⑩	⑪	
① Series	CBG = Cylindrical single nut (ground) CBR = Cylindrical single nut (rolled)					⑦ Thread Direction R = Right-hand L = Left-hand LR = Right- & Left-hand						
② Screw Diameter (mm)	06 = 6mm					⑧ Total Screw Length (mm) Decimal point is indicated by "_"						
③ Lead (mm)	01 = Standard ball lead, 1 mm 01K = Non-standard ball lead, 1 mm					⑨ Accuracy Grade C3 = JIS Standard C3 C5 = JIS Standard C5 C7 = JIS Standard C7 C10 = JIS Standard C10						
④ Ball Return Type	D = Deflector Type S = End Deflector type T = Return Tube type C = End-cap type					⑩ Axial Clearance Z = Preload T = ≤ 0.005 mm S = ≤ 0.02 mm N = ≤ 0.05 mm						
⑤ Custom Option (Non-standard)						⑪ Custom Serial Number						
⑥ Threaded Section Length (mm)	Decimal point is indicated by "_"											

Screw Diameter D (mm / inch)	4 (0.157)	6 (0.236)
Lead (mm / inch)	1 (0.039)	1 (0.039)
Nut Diameter D (mm / inch)	9 (0.354)	13 (0.512)
Nut Overall Length L (mm / inch)	10 (0.394)	14 (0.551)
Keyway Position Dimension (S1) (mm / inch)	-	2 (0.079)
Keyway Length (S) (mm / inch)	-	10 (0.394)
Keyway Width (W) (mm / inch)	-	3 (0.118)
Keyway Depth (H) (mm / inch)	-	1.8 (0.071)
Basic Dynamic Load Rating Ca (N)	560	680
Basic Static Load Rating Coa (N)	790	1200

[MBG · MBR] Metric Thread Single Nut

Part Number Construction										
Example	MBG	06	01	D	X - 60	R	90	C3	Z -	001
	①	②	③	④	⑤	⑥	⑦	⑧	⑨	⑩
① Series	MBG = Metric threaded single nut (ground) MBR = Metric threaded single nut (rolled)					⑦ Thread Direction R = Right-hand L = Left-hand LR = Right- & Left-hand				
② Screw Diameter (mm)	06 = 6mm					⑧ Total Screw Length (mm) Decimal point is indicated by "_"				
③ Lead (mm)	01 = Standard ball lead, 1 mm 01K = Non-standard ball lead, 1 mm					⑨ Accuracy Grade C3 = JIS Standard C3 C5 = JIS Standard C5 C7 = JIS Standard C7 C10 = JIS Standard C10				
④ Ball Return Type	D = Deflector Type S = End Deflector type T = Return Tube type C = End-cap type					⑩ Axial Clearance Z = Preload T = ≤ 0.005 mm S = ≤ 0.02 mm N = ≤ 0.05 mm				
⑤ Custom Option (Non-standard)	⑥ Threaded Section Length (mm) Decimal point is indicated by "_"					⑪ Custom Serial Number				

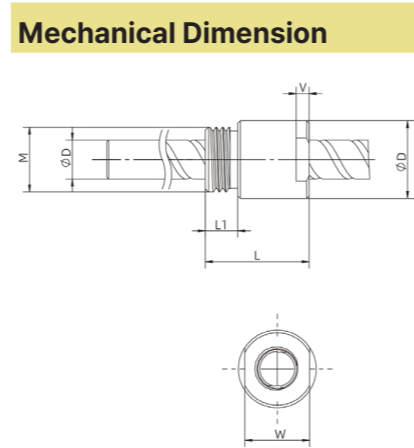

Screw Diameter D (mm / inch)	4 (0.157)	6 (0.236)	6 (0.236)	8 (0.315)	10 (0.394)
Lead (mm / inch)	1 (0.039)	1 (0.039)	2 (0.079)	2 (0.079)	2 (0.079)
Nut Diameter D (mm / inch)	10 (0.394)	12 (0.472)	12 (0.472)	16 (0.63)	19.5 (0.768)
Nut Overall Length L (mm / inch)	16.5 (0.65)	16 (0.63)	16 (0.63)	27 (1.063)	22 (0.866)
Thread Size M (mm)	M8X0.75	M10×0.75	M10X1	M14X0.75	M17X1
Thread Length L1 (mm / inch)	5 (0.197)	5 (0.197)	5 (0.197)	5 (0.197)	8.2 (0.323)
Wrench Flat Width W (mm / inch)	9 (0.354)	10 (0.394)	10 (0.394)	14 (0.551)	-
Wrench Flat Depth V (mm / inch)	1.5 (0.059)	2 (0.079)	2 (0.079)	4 (0.157)	-
Basic Dynamic Load Rating Ca (N)	560	680	880	1300	1500
Basic Static Load Rating Coa (N)	790	1200	1500	2300	2900

[KBG · KBR] Square Single Nut

Part Number Construction										
Example	KBG	06	01	D	X - 60	R	90	C3	Z -	001
	①	②	③	④	⑤	⑥	⑦	⑧	⑨	⑩
① Series	KBG = Square-type single nut (ground) KBR = Square-type single nut (rolled)					⑦ Thread Direction R = Right-hand L = Left-hand LR = Right- & Left-hand				
② Screw Diameter (mm)	06 = 6mm					⑧ Total Screw Length (mm) Decimal point is indicated by "_"				
③ Lead (mm)	01 = Standard ball lead, 1 mm 01K = Non-standard ball lead, 1 mm					⑨ Accuracy Grade C3 = JIS Standard C3 C5 = JIS Standard C5 C7 = JIS Standard C7 C10 = JIS Standard C10				
④ Ball Return Type	D = Deflector Type S = End Deflector type T = Return Tube type C = End-cap type					⑩ Axial Clearance Z = Preload T = ≤ 0.005 mm S = ≤ 0.02 mm N = ≤ 0.05 mm				
⑤ Custom Option (Non-standard)	⑥ Threaded Section Length (mm) Decimal point is indicated by "_"					⑪ Custom Serial Number				

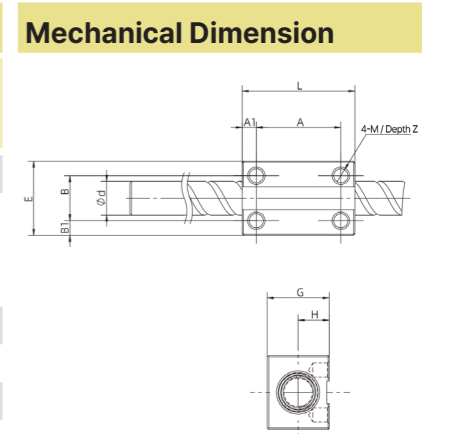

Screw Diameter D (mm / inch)	6 (0.236)	8 (0.315)	8 (0.315)
Lead (mm / inch)	1 (0.039)	1 (0.039)	1 (0.039)
Nut Overall Length L (mm / inch)	20 (0.787)	20 (0.787)	22 (0.866)
Nut Width E (mm / inch)	13 (0.512)	14 (0.551)	15 (0.591)
Nut Height G (mm / inch)	11 (0.433)	13 (0.512)	13 (0.512)
Mounting Hole Size B1 (mm / inch)	2.5 (0.098)	3 (0.118)	1.5 (0.059)
Mounting Hole Pitch B (mm / inch)	8 (0.315)	8 (0.315)	12 (0.472)
Mounting Hole Size A1 (mm / inch)	2.5 (0.098)	2.5 (0.098)	2.5 (0.098)
Mounting Hole Pitch A (mm / inch)	15 (0.591)	15 (0.591)	17 (0.669)
Tapped Hole M / Depth Z	M3 / Depth3.5	M2.5×0.45 / Depth 3	M2.5×0.45 / Depth 3
Basic Dynamic Load Rating Ca (N)	680	780	780
Basic Static Load Rating Coa (N)	1200	1650	1650



ENG Web



Partners Web



YouTube



## HEADQUARTERS

### Jiangsu DINGS' Intelligent Control Technology Co., Ltd.

No. 2850 Luheng Road, Changzhou Economic Development Zone, Jiangsu Province, China

Tel : +86-519-85177826

E-mail : info@dingsmotion.com

www.dingsmotion.com

## GLOBAL MANUFACTURING LOCATION

### DINGS' Intelligent Control Technology (Thailand) Co., Ltd.

42/29 Moo 4, Uthai Subdistrict, Uthai District, Phra Nakhon Si Ayutthaya 13210, Thailand

Tel : +66 64-505-9951

## SUBSIDIARIES

### DINGS' Motion USA

355 Cochrane Circle Morgan Hill,  
CA 95037

+1-408-612-4970

sales@dingsmotionusa.com

dingsmotionusa.com

### DINGS' Motion Europe

4 Avenue du Grand Trémoutier  
44120 Vertou, France

+33-(0)6-41-37-80-07

sebastien@dingsmotion.com

fr.dingsmotion.com

### DINGS' Korea Co., Ltd.

C-702, 158 Haneulmaeul-ro, Ilsandong-gu,  
Goyang-si, Republic of Korea

+82-31-994-0755

daniel@dingsmotion.com

dingsmotion.kr / dkps.co.kr / en.dkps.co.kr

## INTERNATIONAL OFFICES

### DINGS' Shenzhen Office

Room 1105, Block C, CIMC Industry Park,  
Guangming District, Shenzhen, China

info@dingsmotion.com

### DINGS' JAPAN

101, 2-27-18, Nishi-kojiya, Ota-ku, Tokyo  
144-0034 JAPAN

+81-90-7730-0034

tsukahara@dingsmotion.com

jp.dingsmotion.com

Catalog Issued: June 2026

© DINGS'. All rights reserved

No part of this catalog may be reproduced or distributed without prior written consent from DINGS'. Specifications, features, and designs are subject to change without prior notice for product improvement.

DINGS' reserves the right of final interpretation of this catalog and its products.